

# THE PERFORMER™ HIGH-EFFICIENCY WOODSTOVE

EPA Certified (3.89 grams/hr.)

## Model TR009 Owners Manual (save this manual for future reference)



**READ ALL INSTRUCTIONS CAREFULLY BEFORE INSTALLING OR OPERATING THIS STOVE. FAILURE TO FOLLOW INSTRUCTIONS MAY RESULT IN PROPERTY DAMAGE, BODILY INJURY, OR EVEN DEATH.**



OMNI-Test Laboratories, Inc.

**This stove meets  
U.S. Test Standard:  
UL 1482-2006**

**DO NOT USE THIS STOVE IN A  
MOBILE HOME, MANUFACTURED HOME,  
TENT OR TRAILER – *NO EXCEPTIONS!***

# VOGELZANG

*International* CORPORATION



*Vogelzang International Corporation*

*400 West 17th Street*

*Holland, Michigan 49423*

*www.vogelzang.com*

*Phone: 1-616-396-1911*

*Fax: 1-616-396-1971*

# SAFETY INSTRUCTIONS

**SAFETY NOTICE: IF THIS STOVE IS NOT PROPERLY INSTALLED, A HOUSE/BUILDING FIRE MAY RESULT. FOR YOUR SAFETY, CONTACT LOCAL BUILDING OR FIRE OFFICIALS ABOUT PERMITS, RESTRICTIONS, AND INSTALLATION REQUIREMENTS FOR YOUR AREA.**

## READ ALL INSTRUCTIONS CAREFULLY.

1. The installation of this stove must comply with your local building code rulings. Please observe the clearances to combustibles (see reference figures 10–12). Do not place furniture or other objects within the clearance area.
2. Verify that the stove is properly installed before firing the stove for the first time. After reading these instructions, if you have any doubt about your ability to complete your installation properly, you must obtain the services of a professional licensed installer familiar with all aspects of safe and correct installation. **DO NOT** use temporary or makeshift compromises during installation.
3. **DO NOT** store wood, flammable liquids or other combustible materials too close to the unit. Refer to certification label on back of unit and reference figures 10–12 in this manual.
4. **Do not install this stove in a mobile home, manufactured home, trailer or tent NO EXCEPTIONS! (HUD Federal Standard: 24 CFR Ch.XX).**
5. If any parts are missing or defective, please notify the dealer or manufacturer immediately. **DO NOT OPERATE A STOVE THAT IS MISSING ANY PARTS!**
6. Do not tamper with combustion air control beyond normal adjustment capacities.
7. Always connect this stove to a chimney and vent to the outside. Never vent to another room or inside a building. **DO NOT CONNECT THIS UNIT TO A CHIMNEY FLUE SERVING ANOTHER APPLIANCE.**
8. Do **NOT** connect a wood burning stove to an aluminum Type B gas vent. This is not safe. Use a code-approved masonry chimney with flue liner or a UL 103 HT Listed Residential Type and Building Heating Appliance Chimney. Use a 6" diameter chimney or larger, that is high enough to give a good draft (see specifics in installation instructions).
9. Be sure that your chimney is safely constructed and in good repair. Have the chimney inspected by the fire department or a qualified inspector. Your insurance company should be able to recommend a qualified inspector.
10. Creosote or soot may build up in the chimney connector and chimney and cause a house/building fire. Inspect the chimney connector and chimney twice monthly during the heating season and clean if necessary. (See Service Hints, page 15).
11. In the event of a chimney fire, turn the air control to closed position, leave the building and **CALL THE FIRE DEPARTMENT IMMEDIATELY!** Have a clearly understood plan on how to handle a chimney fire by contacting your local fire authority for information on proper procedures in the event of a chimney fire. After the fire is out, the chimney must be cleaned and inspected for any stress or cracks before starting another fire. Check the condition of any combustibles surrounding the chimney.
12. To prevent injury, do not allow anyone to use this stove who is unfamiliar with the correct operation of the stove.
13. Do not operate stove while under the influence of drugs or alcohol.
14. Ashes should not be allowed to accumulate above sides of ash drawer. Dispose of ashes in a metal container with a tight fitting lid. Keep the closed container on a noncombustible floor or on the ground, well away from all combustible materials. Keep the ashes in the closed container until all cinders have thoroughly cooled. The ashes may be buried in the ground or picked up by a refuse collector.
15. The special paints used on your stove may give off some smoke and an odor while they are curing during the first 12 to 15 fires. Additional smoke and odor may be emitted from the light oils used in construction of the fire box. This should disappear after a short period of time and not occur again. Persons with lung conditions or owners of susceptible domestic pets (such as birds) should take prudent precautions. Open windows and doors as needed to clear smoke and/or odor. Paint discoloration will occur if the stove is over fired.
16. This stove has a painted surface which is durable but it will not stand rough handling

*continued on next page*

## SAFETY INSTRUCTIONS *continued...*

---

or abuse. When installing your stove, use care in handling. Clean with soap and warm water when stove is not hot. Do not use any acids or scouring soap, as these solvents wear and dull the finish.

17. While stove is in operation all persons, especially young children, should be alerted to the hazards from high surface temperatures. Keep away from a hot stove to avoid burns or clothing ignition.
18. If small children will be in the same room as the stove during operation, provide a sturdy barrier to keep them at a safe distance from the stove. **NEVER LEAVE SMALL CHILDREN UNSUPERVISED WHEN THEY ARE IN THE SAME ROOM AS THE STOVE.**
19. The walls of the firebox may become slightly distorted after a period of use. A slight distortion will not affect the operation of the stove.
20. Keep stove area clear and free from all combustible materials, gasoline, and other flammable vapors and liquids.
21. To prevent burns always wear protective clothing, leather hearth gloves and eye protection, while tending the fire.
22. While in operation, keep the ash clean out cover in place. Keep the feed door closed and secured at all times except while tending the fire.
23. Do not over fire the stove. Over firing will occur if the feed door or ash clean-out cover are left open during operation. Such actions can result in very dangerous operating conditions.
24. Do not load the fuel to a height or in such manner that it would be hazardous when opening the door.
25. **DO NOT ELEVATE FIRE!** Build fire directly on the bottom of the firebox. This stove has not been tested with the use of grates, andirons, or other means of elevating fire and should not be used.
26. All power cords and electrical appliances and/or assemblies must be kept outside of the clearance dimensions shown in this manual for combustible materials.
27. For further information on using your stove safely, obtain a copy of the National Fire Protection Association (NFPA) publication, "Using Coal and Wood Stoves Safely" NFPA No. HS-10-1978. The address of the NFPA is Batterymarch Park, Quincy, MA 02269.

**NOTE: A PROFESSIONAL, LICENSED HEATING AND COOLING CONTRACTOR MUST BE CONSULTED IF YOU HAVE QUESTIONS REGARDING THE INSTALLATION OF THIS SOLID FUEL BURNING APPLIANCE.**

# TABLE OF CONTENTS

---

SAFETY PRECAUTIONS.....	2 – 3
TOOLS AND MATERIALS REQUIRED FOR INSTALLATION .....	5
ASSEMBLY INSTRUCTIONS .....	5
LOCATING THE STOVE .....	7
Floor Protector, Minimum Clearances .....	7 – 8
FIRE BRICK ASSEMBLY .....	8
CONNECTOR PIPE INSTALLATION .....	9
CHIMNEY SIZING .....	9
CHIMNEY CONNECTIONS/DRAFT.....	10 –12
OPERATING INSTRUCTIONS	
House Fire Hazards, Operating Precautions, Warnings .....	13
Wood Types/Sizes.....	13
Optimal Fuel Consumption .....	13
Starting a Fire, Adding Fuel .....	14
SERVICE HINTS	
Creosote Formation, Prevention, Removal .....	15
Chimney Draft .....	16
Glass Care & Replacement, Glass Gasket Replacement .....	17
PARTS – PERFORMER™ .....	18
PARTS – GLASS DOOR (Glass Replacement).....	19
PARTS – FIRE BRICK.....	19
OPTIONAL F-6 BLOWER WIRING DIAGRAM .....	20
FLOOR PROTECTOR CALCULATIONS .....	21
CHIMNEY CONNECTION SYSTEMS & CLEARANCES.....	22

# ASSEMBLY INSTRUCTIONS

**NOTICE:** Vogelzang International Corp. grants no warranty, stated or implied, for the installation or maintenance of your wood stove and assumes no responsibility of any incidental or consequential damages.

## TOOLS AND MATERIALS REQUIRED FOR INSTALLATION

### TOOLS

- Pencil
- 6 foot Folding Rule or Tape Measure
- Tin Snips
- Drill: Hand or Electric
- 1/8" dia. Drill Bit (for sheet metal screws)
- Screwdrivers (blade and Phillips type)
- 10mm Nut Driver or Ratchet with 10mm Socket
- 11/16" socket or wrench
- Safety Glasses
- Gloves

### MATERIALS

(NOTE: The following items are NOT included with your stove)

Flooring Protection: 36" x 48" as specified (see page 7)

Chimney Connection: 6" dia. minimum 24 MSG black or 26 MSG blue steel straight stove pipe or elbow(s) as required.

1/2" Sheet Metal Screws

Chimney: Existing 6" Code-approved Lined Masonry Chimney or 6" Inside Dia. Listed Type HT manufactured chimney.

Furnace Cement (manufacturer recommends Rutland Code 78 or equivalent)

**CAUTION: STOVE IS HEAVY. MAKE SURE YOU HAVE ADEQUATE HELP AND USE PROPER LIFTING TECHNIQUES WHENEVER MOVING STOVE.**

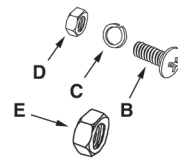
1. Uncrate the stove and remove all cardboard and styrofoam packing materials and protective poly bag. Remove pedestal base, sides, front, top, ash drawer and ash drawer support from the carton. (Save packing materials for further assembly.)

**NOTICE: DO NOT remove ceramic blanket material** from inside stove pipe opening (Fig. 1). This blanket provides an air seal on the side walls



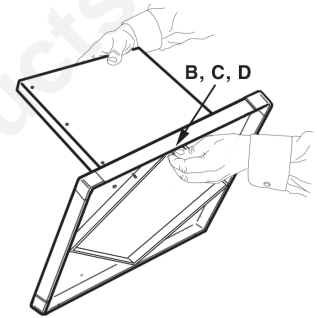
**Figure 1 – DO NOT remove ceramic blanket from inside stove pipe opening. This is NOT packing material but an integral component of the stove combustion system.**

of the stove to direct combustion gasses over the secondary combustion tubes before exiting via the chimney. **DO NOT REMOVE the ceramic blanket** or your stove will not operate properly.

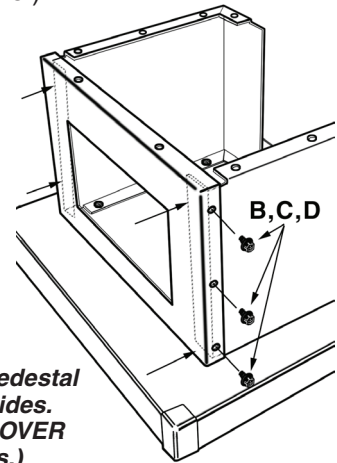


**Figure 2 – Pedestal Assembly Hardware. 1/4-20 machine screws, lock washers & hex nuts**

**Figure 3 – Assemble sides to base**



2. Remove parts and hardware pack located inside firebox.
3. Align the hole pattern of one of the pedestal sides to the holes in the base and secure with four (4) machine screws, lock washers and hex nuts. Assemble the opposite side to the base. (Note: Sides are interchangeable.)

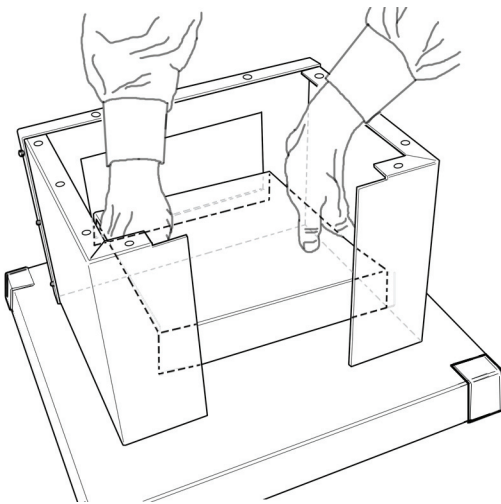


**Figure 4 – Attach Pedestal Front Frame to Sides. (Note– front goes OVER the side panels.)**

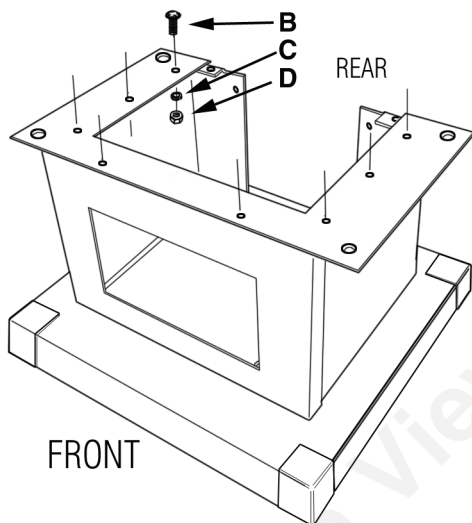
4. Attach the pedestal front frame to the sides. The pedestal front should go **over** (not inside of) the side panels. Use three (3) machine screws, lockwashers & hex nuts (provided in the hardware pack) on each side to attach both pedestal sides (#31) to the pedestal front (#32).
5. Position ash drawer support into assembled pedestal (Figure 5) and secure from rear with two (2) machine screws, lock washers and hex nuts. Tighten all pedestal hardware.

*continued on next page*

# ASSEMBLY INSTRUCTIONS . . . continued

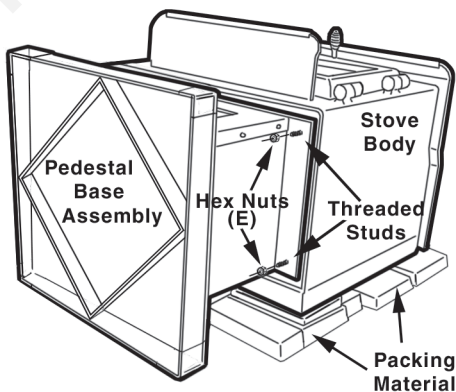


**Figure 5 – Insert Ash Drawer Support.**



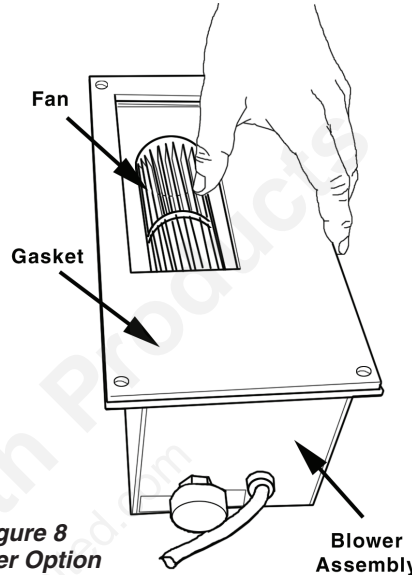
**Figure 6 – Attach Pedestal Top.**

6. Position the pedestal top and attach with eight (8) machine screws, lock washers and hex nuts. (See Figure 6)
7. Place flattened carton/styrofoam packing material on floor and carefully tip the stove body onto it's back.



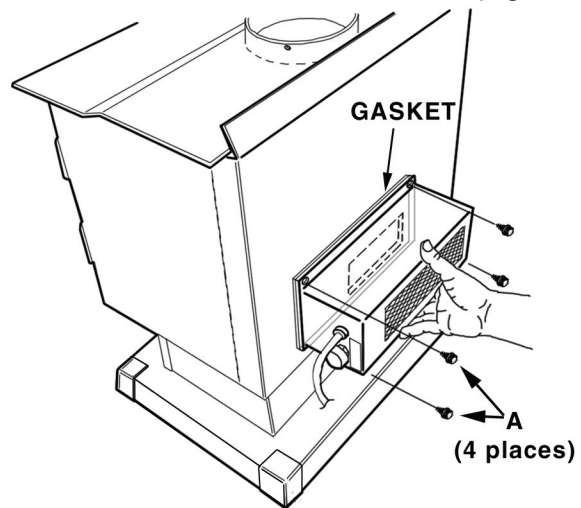
**Figure 7 – Attach Pedestal to Stove Body**

8. Align four (4) corner mounting studs with holes in pedestal top (Figure 7). Secure with four (4) hex nuts (E).
9. Tip the stove assembly upright.
10. Set the ash drawer inside the open box formed by the pedestal front and sides.



**Figure 8  
Blower Option**

11. For Optional Blower Assembly, note the position of the blower opening in the rear of the stove.
12. Place blower gasket onto blower assembly so as not to obstruct the air flow from the fan (Figure 8).



**Figure 9 – Attach Optional Blower to Stove Body**

13. Mount the blower assembly to the back of the stove aligning the fan opening to the opening in the back of the stove. Secure with four sheet metal screws.
14. After assembly, check to make sure fire brick are properly positioned and ash clean out cover is in place.

# LOCATING STOVE

- The stove must be placed on solid concrete, solid masonry, or when installed on a combustible floor, on a listed floor protector, such as Hy-C or Imperial Model UL3648BK or equivalent. Floor protector must be 1/2" minimum thickness (R value = 0.84, see page 21 for calculation formulas) non-combustible material or equivalent. The base must extend at least 16" beyond the front of the access door, 6" to the sides of fuel opening, and 11" beyond the rear. It must extend under and 2 inches beyond either side of the stove pipe if it is elbowed towards a wall. (See figures 10 & 12 and consult local building codes and fire protection ordinances.)

**CAUTION: FIRE HAZARD. CARPETING AND OTHER COMBUSTIBLE MATERIAL SHALL NOT COVER THE FLOOR PROTECTOR. THESE MATERIALS MUST REMAIN OUTSIDE OF COMBUSTIBLE CLEARANCES, SEE FIG. 10-12**

- The stove must have its own flue. Do not connect this unit to a chimney flue serving other appliances.
- After observing the clearances to combustible materials (figures 10–12), locate your floor protector accordingly (figure 10) and carefully place the stove in your selected location. Install connector pipe, elbows, and thimble as required, utilizing either a recently cleaned and inspected 6" lined masonry chimney or a 6" i.d. listed manufactured chimney.
- Use round 6" dia., minimum 24 MSG black or 26 MSG blue steel stove pipe to connect the stove

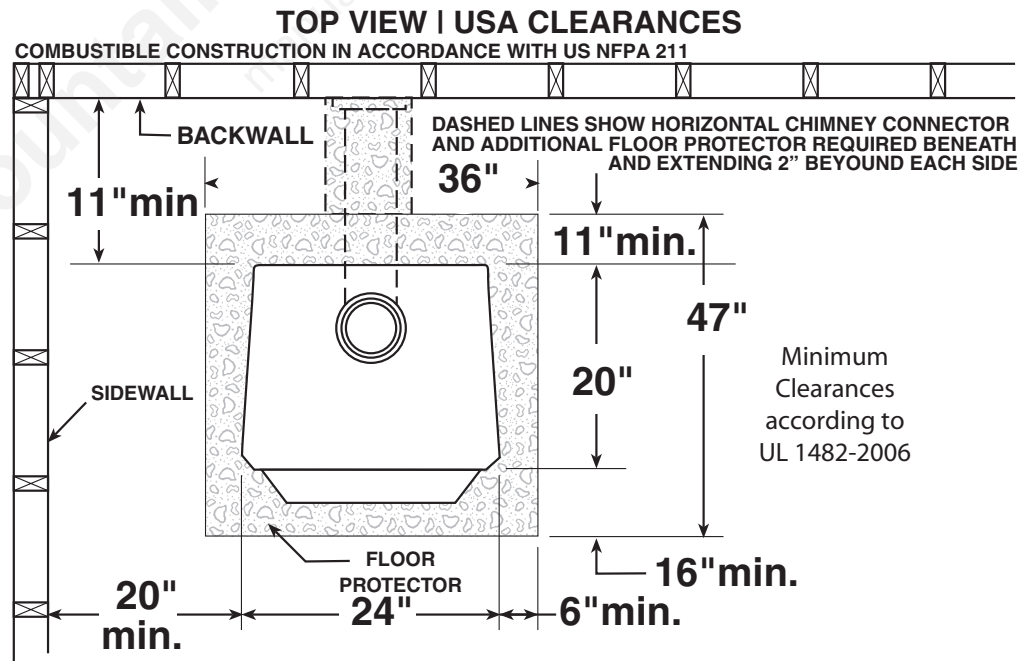
to the chimney. Do not use galvanized stove pipe. Secure connector pipe to the flue collar with three (3) sheet metal screws. Use three screws in each stove pipe and/or elbow joint to firmly hold the pipe sections together. DO NOT connect this stove to any air distribution or duct system.

- Recheck clearances from the stove, connector stove pipe, and corner clearances using the illustrations in figures 10–12 and your local building codes or fire protection ordinances.

**NOTE: ANY WALL CONTAINING COMBUSTIBLE MATERIAL SUCH AS WOODEN STUDS OR DRYWALL AND FACED WITH BRICK OR STONE MUST BE CONSIDERED A COMBUSTIBLE SURFACE.**

- DO NOT install this stove in a mobile home, Manufactured Home, Tent or trailer – NO EXCEPTIONS! (HUD Federal Standard: 24 CFR Ch.xx)
- The clearances provided are minimum dimensions set by UL standard 1482, tested and applied by OMNI-Test Laboratories, Inc. the manufacturer's testing agency. Installation of this stove must comply with the latest edition of NFPA 211 for reduced clearances and/or your local building code rulings. Use whichever minimum dimensions are LARGEST.

*continued on next page*



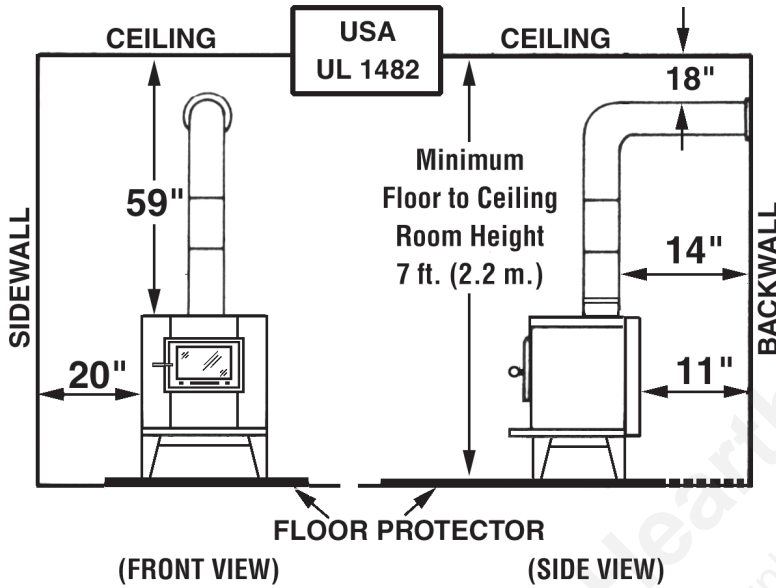
**Fig. 10 – TOP VIEW Minimum Clearance Dimensions from Combustible Surfaces**

# LOCATING STOVE continued...

8. This stove meets U.S. Test Standard: UL 1482-2006.

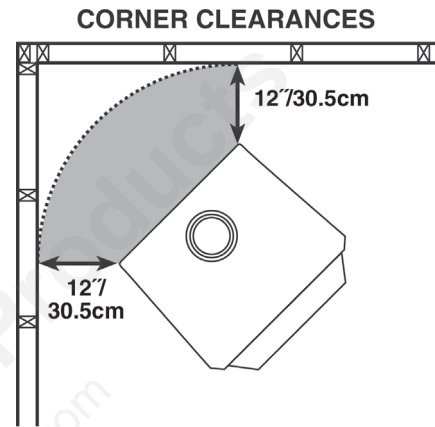
**CAUTION: KEEP FURNISHINGS AND OTHER COMBUSTIBLE MATERIALS AWAY FROM THE STOVE.**

**NOTE: BEFORE FIRING WOODSTOVE SLIDE FIREBRICKS TOWARDS THE REAR SO NO GAPS REMAIN BETWEEN BRICKS.**



**Figure 11a – Front View**  
Minimum Clearance Dimensions  
from Combustible Surfaces

**Figure 11b – Side View**  
Minimum Clearance Dimensions  
from Combustible Surfaces

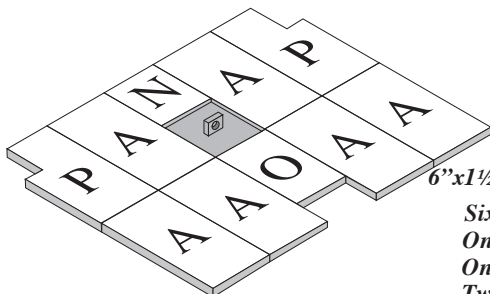


**Figure 12 – Top View**  
Minimum Corner Clearances  
from Combustible Surfaces

## FIREBRICK ASSEMBLY

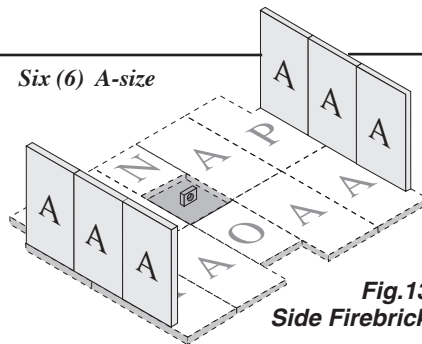
Firebrick extends the life of your stove and radiates heat more evenly. Check to see that all firebricks are in their correct positions and have not become misaligned during shipping or assembly. If removed for ease of locating stove, firebrick must be replaced before firing. See diagrams, fig. 13a – 13c, for proper positioning.

**CAUTION: NEVER OPERATE STOVE WITH MISSING OR CRACKED FIRE BRICKS!**

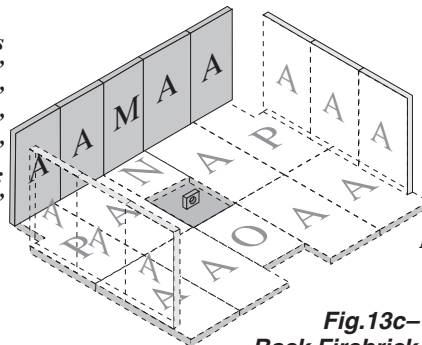


**Figure 13a – Step 1, Bottom Firebrick Arrangement**

- Fire Brick Dimensions**  
 A-size: 9"x4½"x1¼"  
 M-size: 9"x2¼"x1¼"  
 N-size: 4½"x4½"x1¼"  
 O-size: 6¾"x4½"x1¼"  
 P-size: 6"x1½"x3"x3"x9"x4½"x1¼"  
 Six (6) A-size  
 One (1) C-size  
 One (1) D-size  
 Two (2) E-size



**Fig. 13b– Step 2,**  
Side Firebrick Arrangement



**Fig. 13c– Step 3,**  
Back Firebrick Arrangement

# CONNECTOR PIPE INSTALLATION

Connector pipe is used to make the connection from the final positioning of your stove to an approved chimney. Connector pipe is NOT included as part of the stove. Connector pipe must be 6" diameter minimum of 24 MSG (minimum standard gauge) black or 26 MSG blue steel stove pipe. Connector pipe is not rated to provide close contact to combustible materials and must have proper clearance from combustible materials as shown in the clearance diagrams on the previous pages. Connector pipe should never be used in place of a chimney. If proper clearances are not observed a house fire could result.

## INSTALLATION INSTRUCTIONS

1. The crimped end of the stovepipe fits inside the stove flue collar. Secure with three (3) sheet metal screws. The first section of connector pipe must be single walled to properly attach to the stove collar. Install additional pipe and elbow with the crimped end towards the stove. This will allow any condensation in the flue to run back into the firebox.
2. Horizontal pipe runs must slope upwards towards the chimney at least 1/4" per foot of horizontal run.

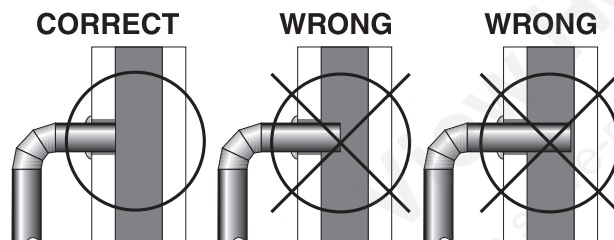


Figure 14 – Stovepipe/Flue Connections

3. You must have at least 18 inches of clearance between any horizontal piping and the ceiling.
4. The pipe cannot extend into the chimney flue (figure 14).
5. Secure pipe/elbow sections with three (3) sheet metal screws at each joint to make the piping rigid.
6. It is recommended that no more than two (2) 90° bends be used in the stovepipe installation. The use of more than two 90° bends may decrease the amount of draw and possibly cause smoke spillage. Where possible, use only corrugated (non adjustable) elbows. These provide a better seal.
7. The connector pipe must not pass through an attic or roof space, closet, or any concealed space, floor, ceiling, wall, or combustible construction. (See Chimney Connector Systems & Clearances, page 22.) A UL 103 HT Listed chimney must be used from the first penetration of ceiling or wall to the chimney cap.

**CAUTION: NEVER USE SINGLE WALL CONNECTOR PIPE AS A CHIMNEY - A HOUSE FIRE COULD RESULT.**

**NOTE: CONNECTOR PIPE IS *NOT INCLUDED*. TO PURCHASE, VISIT YOUR LOCAL HARDWARE, HOME, OR BUILDING CENTER. SEE "LOCATING STOVE" PAGE 7 FOR ADDITIONAL SPECIFICATIONS.**

## CHIMNEY SIZING

Today's solid fuel heating appliances are much more efficient than those made in the past. Your heating appliance has been designed to provide the most efficient transfer of heat possible from the least amount of fuel.

Controlled combustion is the key to optimum heating performance. Controlled combustion requires a flow of fresh air into the appliance, across the fuel and is finally exhausted up the chimney.

Today's high efficiency stoves transfer more heat into the living area and less up the chimney. Exhaust gases are typically at a lower temperature than traditional type stoves. With lower exhaust temperatures, it is important that the chimney is correctly sized to the stove. If the chimney diameter is too large, it will be dif-

ficult to raise the chimney flue temperature to provide for adequate draft. This may result in a poor burn, smoke spillage, and rapid creosote creation. A 6" diameter chimney is best suited for this stove.

Your heating appliance must have a minimum of a 6" diameter (152mm) chimney. Maximum chimney diameter must not exceed 10" (254mm) or have a cross sectional area greater than 85 sq. in. (550cm<sup>2</sup>.)

Proper draft for this heating appliance is minimum of 0.05 w.c. (water column measurement) and is required to prevent back puffing, smoke spillage and prevent safety hazards.



# CHIMNEY CONNECTIONS *continued ...*

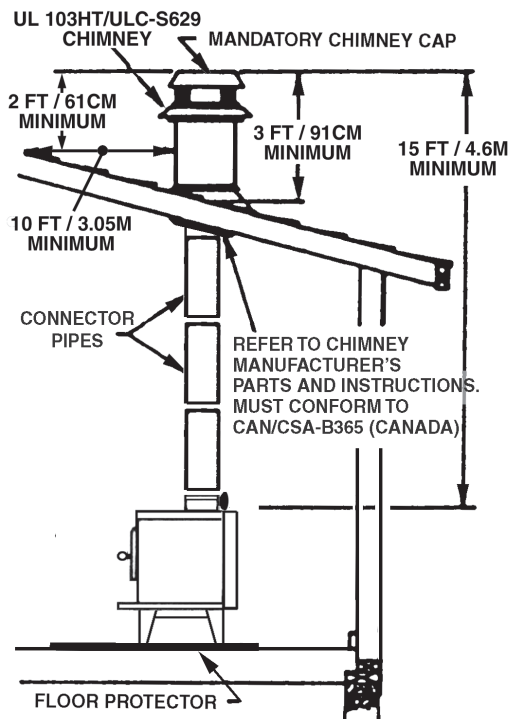


Figure 17 - Chimney Construction through Roof

## Chimney Minimum Height Requirements:

- (1) Overall Height – 15 ft. min.
- (2) Height above roof – 3 ft
- (3) Height above slope – 2 ft. min. within 10 ft.
- (4) Minimum rise before horiz. section – 24 in.

**NOTICE: If minimum chimney requirements are not met, your stove will not operate properly.**

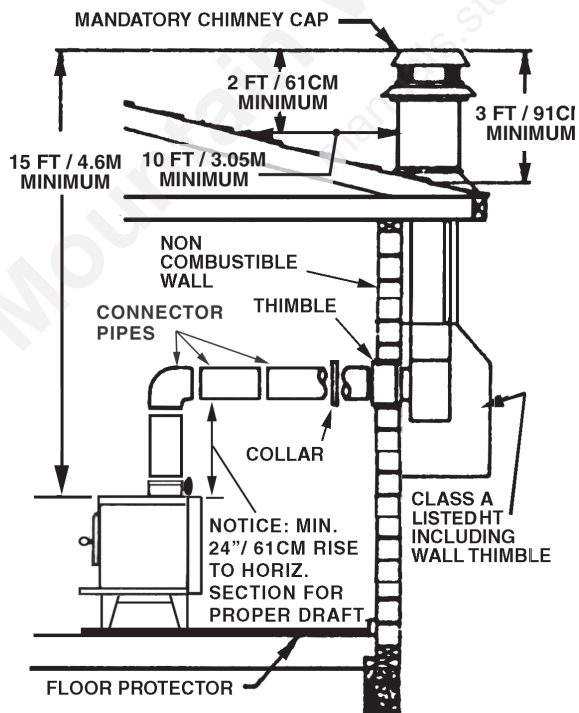


Figure 18 - Chimney Connection to Firebox through Masonry Wall

## MANUFACTURED CHIMNEY

REFER TO CHIMNEY AND CHIMNEY CONNECTOR MAKER'S INSTRUCTIONS FOR INSTALLATION AND USE.

Use only 6" diameter listed chimney UL 103 HT. Chimney made to this listing is High Temperature rated to 2100 degrees Fahrenheit. Use chimney from only one manufacturer. Never mix brands. Carefully follow the chimney manufacturer's stated requirements and clearances. Use the chimney manufacturer's attic guards, roof supports, flashing and fire stops when passing through a ceiling. Use a listed thimble when passing through a combustible wall. Do not use makeshift compromises during installation. Never use a single-wall connection pipe as a chimney!

When using a pre-existing chimney, have it's condition and installation inspected before using. Make sure that the chimney meets all of the UL rating requirements listed above. Be aware that not all manufactured chimney is of the UL 103 HT type.

NOTE: It is recommended that you contact a licensed heating and cooling contractor (consult your local yellow pages) for chimney installation.

Manufactured chimney with the proper required UL listing is available from most home centers, hardware stores, and HVAC supply stores.

If you have access to the internet, you may wish to view chimney manufacturers' information on-line. See, [www.duravent.com](http://www.duravent.com), [www.selkirkinc.com](http://www.selkirkinc.com), or [www.mtlfab.com](http://www.mtlfab.com).

## VENTING TO EXISTING FIREPLACE

In some instances, people desire to convert an existing fireplace for stove use. Usually, safe connection to an existing masonry chimney requires more work than using a prefabricated chimney. The existing fireplace must be closed and sealed at the damper with high-temperature caulk, ceramic wool, or furnace cement. Prior to installation, clean and inspect the existing flue and smoke shelf. Installation should be designed so the system can be dismantled for periodic cleaning and inspection. **Before conversion, make sure the existing chimney is structurally sound, the chimney incorporates a flue liner and make sure it is in good condition.** (A flue liner consists of clay tile that protects the brickwork of a chimney. If a chimney does not have a liner, or it is damaged, have it relined by a professional. **Do Not use a chimney that is unlined or damaged!**) If you have any question regarding the condition of the chimney, consult a qualified licensed contractor, qualified engineer, competent mason, certified Chimney Sweep, or a knowledgeable inspector.

*continued on next page*

# CHIMNEY CONNECTIONS *continued ...*

Consult your insurance company if you cannot find a qualified expert.

**CAUTION: NOT ALL FIREPLACES ARE SUITABLE FOR CONVERSION TO A WOOD STOVE. CHECK WITH A QUALIFIED EXPERT.**

Many prefabricated fireplaces are of the “zero-clearance fireplace” category. These consist of multi-layered metal construction. They are designed with enough insulation and/or air cooling on the base, back and sides so they can be safely installed in direct contact with combustible floors and walls. Although many prefabricated fireplaces carry endorsements from nationally recognized organizations for use as fireplaces, they have not been tested for connection to wood stove heaters. Connecting a stove to such a device will void the manufacturer’s warranty.

Steel-lined fireplaces are constructed with 1/4” firebox liner, an air chamber in connection with 8” of masonry. These can be safely used with wood burning stoves. They contain all the essential components of a fireplace, firebox, damper, throat, smoke shelf, and smoke chamber. Many look identical to masonry fireplaces and should be checked carefully before connecting a stove to them.

Venting a stove directly into a fireplace does not meet code and should not be attempted. (This constitutes connection to another appliance - the fireplace.) Combustion products will be deposited and build up in the firebox or fireplace. The stove warranty will be void with such an installation. Do not create a hazard in your home by connecting in this manner.

## FIREPLACE INSTALLATION

**NOTE: DO NOT ATTEMPT TO ROUTE THE CHIMNEY CONNECTOR PIPE THROUGH THE THROAT OF THE FIREPLACE.** Directly connecting the stovepipe into the existing masonry chimney (figure 19 “Type A”

fireplace conversion) of the fireplace is the **ONLY** approved method of installation. This is a complicated and involved process and to ensure safety should only be done by a qualified installer.

1. An entry hole must be cut through the masonry and tile liner with minimal damage to the liner. At least 8” of liner must remain below the entry position. When locating the stove and stovepipe, all minimum clearances must be observed from combustible surfaces including mantels, combustible trim work, ceilings, and walls. Positioning the center of the stove pipe entry into the chimney 24” below the ceiling should insure proper clearance for a 6” stovepipe.
2. Install a metal or fire clay (5/8” minimum thickness) thimble. Make sure the thimble is flush with the inner surface of the chimney liner and does not protrude into the flue (see figure 14 on page 9).
3. Secure the thimble with refractory mortar. The thimble should be surrounded by 8” of solid unit masonry brickwork or 24” of stone.
4. Install the stovepipe into the thimble as far as possible without extending past the flue lining (see figures 14 & 15 on pages 9 & 10).
5. A small airspace (about 1/2”) should remain between the stovepipe and thimble to allow for expansion of the pipe. Seal this airspace with high-temperature caulking or ceramic wool.
6. Secure and seal the damper in the closed position using high-temp caulking, ceramic wool, or furnace cement. Also check to see if the chimney has a clean out. If it does, make sure it is closed and sealed as well. A leaky clean out will greatly reduce draft efficiency.

If you have any questions regarding venting your stove, contact the manufacturer or contact the National Fire Protection Association (NFPA) and request a copy of the latest editions of NFPA Standard 211 and NFPA Standard 908. Their address is:

Battery March Park, Quincy, MA 02269.

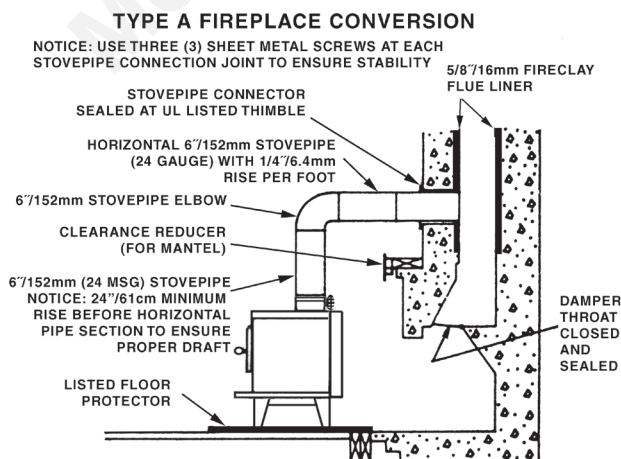


Figure 19 - Fireplace Conversion

# OPERATING INSTRUCTIONS

## CAUTION: HOUSE FIRE HAZARDS

- DO NOT STORE WOOD ON FLOOR PROTECTOR, UNDERNEATH STOVEPIPE, OR ANYWHERE WITHIN MINIMUM CLEARANCES FROM COMBUSTIBLE SURFACES SPECIFIED FOR THIS STOVE.
- OVER FIRING MAY CAUSE A HOUSE FIRE. YOU ARE OVER FIRING IF A UNIT OR CHIMNEY CONNECTOR GLOWS RED.

## OPERATING SAFETY PRECAUTIONS

1. NEVER OVER FIRE THIS STOVE BY BUILDING EXCESSIVELY HOT FIRES AS A HOUSE/BUILDING FIRE MAY RESULT. YOU ARE OVER FIRING THE STOVE IF UNIT OR STOVEPIPE BEGINS TO GLOW OR TURN RED.
2. NEVER BUILD EXTREMELY LARGE FIRES IN THIS TYPE OF STOVE AS DAMAGE TO THE STOVE OR SMOKE LEAKAGE MAY RESULT
3. ON MODELS WITH GLASS DOOR, DO NOT BUILD FIRE TOO CLOSE TO GLASS.
4. UNIT IS HOT WHILE IN OPERATION. KEEP CHILDREN, CLOTHING, AND FURNITURE AWAY. CONTACT MAY CAUSE SKIN BURNS. DO NOT TOUCH THE STOVE AFTER FIRING UNTIL IT HAS COOLED.
5. PROVIDE AIR INTO THE ROOM FOR PROPER COMBUSTION.
6. INSPECT STOVEPIPE EVERY 60 DAYS. REPLACE IMMEDIATELY IF STOVEPIPE IS RUSTING OR LEAKING SMOKE INTO THE ROOM.

## WARNING: EXPLOSION HAZARD

- NEVER USE CHEMICALS, GASOLINE, GASOLINE-TYPE LANTERN FUEL, KEROSENE, CHARCOAL LIGHTER FLUID, OR SIMILAR FLAMMABLE LIQUIDS TO START OR “FRESHEN-UP” A FIRE IN THE STOVE.
- KEEP ALL FLAMMABLE LIQUIDS, ESPECIALLY GASOLINE, OUT OF THE VICINITY OF THE STOVE — WHETHER IN USE OR IN STORAGE.

## THIS STOVE IS DESIGNED TO BURN WOOD FUEL ONLY!

Hardwood, 18” to 20” should be split and air dried (seasoned), for 6 months to obtain maximum burning efficiency. Wood should be stored in a dry, well ventilated area.

**NOTICE: USE SOLID WOOD MATERIALS ONLY. DO NOT BURN GARBAGE OR FLAMMABLE FLUIDS. DO NOT USE COAL. THIS STOVE IS NOT DESIGNED TO ACCOMMODATE THE AIR FLOW (DRAFT) NECESSARY TO PROPERLY BURN COAL OR COAL PRODUCTS. DO NOT ELEVATE FIRE OR USE GRATES OR ANDIRONS. BUILD FIRE DIRECTLY ON BOTTOM OF FIREBOX.**

## OPTIMAL FUEL CONSUMPTION

This stove is designed to get the most efficient transfer of heat energy from the wood fuel and radiate it into your living environment. The fire box introduces combustion air through three sources. (1) Immediately beneath the door opening below the window is a Lower Primary Air Orifice (LPAO). (2) The door air inlet control brings air into the firebox and controls the rate of burn (and the amount of heat the stove radiates). (3) The secondary air tubes at the top of the firebox are designed to ignite the combustion gases (smoke) given off by the burning wood and increases the efficiency of the stove and reduces chimney emissions.

Smoke given off by burning fuel consists of very small organic liquid droplets. If these droplets condense, they form a sticky tar-like substance called creosote. When operated properly, this stove is designed to burn these droplets. Burning these droplets releases heat that would otherwise be lost up the chimney as smoke. Following the instructions below will help you operate your stove properly to maximize the stove’s performance. Actual performance is dependent on chimney height, weather, log size, wood species and moisture content. Some experimentation will initially be required to find that “sweet spot” where your stove performs best. The following will give you a starting point to find your optimum settings.

When first loading fuel set the door air inlet control at the wide open position for at least 15–20 minutes. When the stove is working properly you should be able to observe secondary combustion flames above the fuel pieces in front of the secondary air tubes at the top of the firebox. These secondary flames should continue to burn after the primary air inlet is reset from wide open to the desired operating setting. If the flames do not

*continued on next page*

# OPERATING INSTRUCTIONS *continued . . .*

continue to burn, open the air control to re-establish the secondary flames then slowly reset the air control to the desired setting. Initially it may take several attempts to figure your stove out. But once you find the operating “sweet spot” and the correct mix of procedures to get there, only minor adjustments will be necessary.

The best indicator of a properly operating stove is to look for smoke coming out of the chimney. You may see steam emissions that will quickly dissipate. Smoke will thin but continue to drift without totally disappearing. If you do detect smoke emissions, open the air control a little bit, let the stove adjust for 10–15 minutes and re-check your chimney. Remember – visible smoke represents lost heat.

**NOTICE - INITIAL BURNS TO CURE PAINT BECAUSE OF THE HIGH OPERATING TEMPERATURES, THIS STOVE USES A SPECIAL HIGH-TEMP PAINT WHICH REQUIRES A SERIES OF BURNS TO CURE THE PAINT FOR DURABILITY AND A LIFETIME OF SERVICE.**

Proper curing of the high-temp paint requires a series of three initial burns. The stove should be allowed to cool off between each burn. The first two burns should be small fires and low temperatures (250 degrees F) for a duration of 20 minutes each. The third fire should be at a medium-high temperature (500 F to 700 F) for twenty minutes. Provide adequate cross ventilation to clear any smoke or odor caused by initial firings.

## STARTING A FIRE

1. Set air inlet control to fully open position (slide to right). NOTE: Open/High=right, Closed/Low=left.
2. Open the feed door and place several wads of crushed paper in the firebox.
3. Cover the paper with a generous amount of kindling in a teepee fashion and a few small pieces of wood.
4. Ignite the paper and leave the door open slightly. **DO NOT LEAVE STOVE UNATTENDED WITH DOOR OPEN!**
5. Add large pieces of wood as the fire progresses being careful not to overload. (Do not fill firebox beyond firebrick area.) An ideal coal bed of 1 – 2” should be established to achieve optimum performance.
6. This unit is designed to function most effectively when air is allowed to circulate to all areas of the

firebox. TIP: If ash or coals remain in the stove, make sure to clear them away from the Lower Primary Air Orifice (LPAO) and rake a slight (1-to-2 inch wide) trough down the center of the coal bed from front to back prior to loading the fuel.

7. Once fuel has been loaded, close the door and leave the air inlet control fully open until fire is well established (at least 15–20 minutes) being careful not to over fire (if any of the exterior parts of the stove or chimney connections begin to glow you are over firing the stove).
8. Re-adjust the air inlet control to desired burn rate. For “low” setting slide control all the way to left, for “high” slide all the way to right. (If excessive smoke fills the firebox, open air inlet control slightly until flames resume and wood is sufficiently ignited.) The basic rule of thumb is “closed = low,” “half way open = medium” and “fully open = high.”

## ADDING FUEL

If the coal bed is not hot and glowing, rake the coals to the front of the stove, close the door and adjust the air inlet control to the wide open position. Let the coals re-heat for 10–15 minutes. When hot and glowing, spread them out and place your next fuel load into the stove (make sure no coals or ashes block the LPAO). Leave the door air inlet control in the wide open position for 15–20 minutes.

Fuel load size can vary but should be kept 1–2 inches below the secondary air tubes. Also position the fuel to leave space so the air from the inlet can work down between the pieces of fuel. This reduces the time it takes for new fuel to burn properly.

1. When refueling, adjust air inlet control to the fully open position. When fire brightens, slowly and carefully open the door. This procedure will prevent gases from igniting causing smoke and flame spillage.
2. When adding fuel be careful not to hit, bump or damage the ceramic baffle board located at the top of the firebox.
3. Add fuel being careful not to overload or over fire the stove.
4. When adding fuel be careful not to smother the fire. Do not build fires against glass and make sure the coal bed does not obstruct the air inlet. Do not load fuel to a height or in such a manner that it creates a hazard when opening the door.
5. Close the feed door and secure tightly.
6. Adjust the air inlet control as described above.

*continued on next page*

7. Empty ashes regularly. Do not allow ashes to pile up (see Safety Instructions #14 on page 2.)
8. Properly dispose of hot ashes (see Safety Instructions, item #14 on page 2.)
9. Do not over fire the stove (over firing is when any part of the stove exterior or chimney connections glow).

**CAUTION: DO NOT OVER FIRE APPLIANCE. YOU ARE OVER FIRING IF THE CHIMNEY CONNECTORS OR STOVE GLOWS RED. CLOSE THE DOOR AND SHUT DAMPER IMMEDIATELY TO REDUCE THE AIR SUPPLY AND SLOW DOWN THE FIRE.**

**CAUTION: SLOW BURNING FIRES AND EXTENDED USE MAY CAUSE EXCESSIVE CREOSOTE BUILDUP. IGNITION OF CREOSOTE OR OVER FIRING MAY CAUSE A CHIMNEY FIRE. CHIMNEY FIRES BURN EXTREMELY HOT AND MAY IGNITE SURROUNDING MATERIALS. IN CASE OF A CHIMNEY FIRE CALL THE FIRE DEPARTMENT IMMEDIATELY.**

## SERVICE HINTS

### CREOSOTE – FORMATION AND REMOVAL

**CAUTION: RISK OF FIRE** When wood is burned slowly, it produces tar and other organic vapors which combine with expelled moisture to form creosote. The creosote vapors condense in the relatively cool chimney flue of a slow-burning fire and can accumulate on the flue lining. If ignited, this creates an extremely hot fire in the chimney which may ignite surrounding materials resulting in a building fire.

The chimney connector and chimney should be inspected (at least) **twice a month** during the heating season to determine if a creosote buildup has occurred. If it has, it should be removed. Failure to remove creosote may result in ignition and may cause a house/building fire. Creosote may be removed using a chimney brush or other commonly available materials from your local hardware retailer.

Chimney fires burn very hot. If the unit or chimney connector should glow red, reduce the fire by closing the inlet air control and immediately call the fire department.

**CAUTION: A CHIMNEY FIRE MAY CAUSE IGNITION OF WALL STUDS OR RAFTERS WHICH WERE ASSUMED TO BE A SAFE DISTANCE FROM THE CHIMNEY. IF A CHIMNEY FIRE HAS OCCURRED, HAVE YOUR CHIMNEY INSPECTED BY A QUALIFIED EXPERT BEFORE USING AGAIN.**

A fire in the firebox may be smothered by pouring a large quantity of coarse salt, baking soda, or cool ashes on top of the fire.

### PREVENTING CREOSOTE BUILDUP

1. Creosote will inevitably form in your chimney and connector pipe. Following these steps will help reduce the rate of build up.
2. **BURN ONLY SEASONED WOOD** that has dried for at least one year.
3. Burn hardwood rather than softwood. Hardwood is denser or heavier wood and burns hotter.
4. Do not attempt to burn (or mix in) green or wet wood. The use of green or wet wood will cause a rapid build up of creosote. Wood that hisses, sizzles and blackens without igniting in five minutes must be considered too wet to burn.
5. Do not attempt to extend the burn time by using wet wood. Not only does burning wet wood rapidly build up creosote, but it reduces the heat output by up to 25 percent.
6. Burn the stove with the air inlet control wide open for 10-25 minutes every time fresh wood is loaded into the stove. Do not load more than  $\frac{1}{4}$  to  $\frac{1}{2}$  of the fuel capacity at one time. Loading too much wood at once will cause excessive smoke which contains creosote. Mature fires or coals produce very little creosote-producing smoke.
7. Burn with the control open for several minutes at numerous intervals throughout the day, being careful not to over fire the unit. Following this process will help to warm the chimney and reduce the amount of creosote forming condensation within the chimney.
8. Establish a routine for the handling of fuel, firing, and operating the stove. Check daily for creosote build up until experience shows how often you need to clean for safe operation. Be aware that the hotter the fire, the less creosote is deposited and weekly cleanings may be necessary in mild weather even though monthly cleanings may be enough in the colder months.

*continued on next page*

# SERVICE HINTS continued . . .

**WARNING: IN CASE OF CHIMNEY FIRE (1) CLOSE AIR INLET CONTROL (2) GET OUT OF THE HOUSE (3) CALL THE FIRE DEPARTMENT.**

## CHIMNEY DRAFT

The chimney is critical to the proper operation of the stove. **It is the chimney that creates draft; THE STOVE DOES NOT AND CANNOT CREATE DRAFT.** The chimney provides two vital functions for proper stove operation. First, it is the passage to exhaust smoke and hot gases created in the combustion process. Secondly, it supplies the draft (or pressure) to bring oxygen to the fire to sustain combustion. Draft is the natural movement of air or gases through a chimney. Chimney draft comes from the natural tendency for hot (less dense) air to rise. As the hot air rises within the chimney it creates a lower pressure at the bottom of the chimney to which the stove is connected. The higher pressure air outside the stove then rushes into the stove where the lower air pressure level exists, thus bringing oxygen to the fire. This constant flow of air is referred to as the draft. Many factors or combination of factors can act together to build or impede the draft. Without the correct amount of draft, the stove will not operate properly.

If there is excessive draft, an unsafe condition will arise with too much air being drawn into the stove and creating an excessively hot fire. This could cause over firing which runs the risk of igniting structural elements around the stove and chimney.

The most common experience is that of insufficient draft. Under insufficient draft conditions, the fire will be starved for oxygen, improper or incomplete combustion occurs resulting in smoke spillage into the area around the stove. A fire that is starved for oxygen will not burn well. Such a fire will produce excessive smoke that will cool and condense in the chimney creating creosote. Excessive amounts of creosote buildup can ignite causing a chimney fire with the possibility of structural elements igniting as well.

Correct any draft related issues before using the stove. The following are some possible causes of insufficient draft. Please note that one or more factors may play a role in a draft issue and certain factors may change over time as conditions vary.

### 1. Atmospheric Pressure and Air Supply

Atmospheric pressure that affects the draft may occur from outside the structure, inside the structure, or both. High pressure weather (clear and cold) usually produces a better chimney draft than low

pressure (overcast and damp) conditions. Negative pressure can be created inside a home by appliances that expel air from within such as bathroom vents, range hoods, clothes dryers, and forced air furnaces. Do not allow such appliances to overcome the natural draft. Note that newer homes tend to be built more tightly allowing less make up air to seep freely in. Negative pressure may be overcome by opening a nearby door or window. In extreme conditions of negative draft, the airflow in the chimney will reverse direction. This is known as "down drafting."

### 2. Environmental Factors

Wind or air deflecting off external objects such as the roof, neighboring structures, trees, or hills. These can cause a pressure change in the air surrounding the chimney.

### 3. Chimney Temperature

The temperature of the chimney is an important factor in how well it drafts. Warm chimneys draft better than cold chimneys. This is based upon the principle that hot air rises while cold air sinks. Hot gases going up a cold chimney will cool rapidly. Warm the chimney by allowing a hot fire to burn for the first fifteen to thirty minutes after starting the fire. Be careful not to over fire the stove. If any part of the stove or chimney starts to glow, you are over firing the stove. Masonry chimneys will take longer to warm than manufactured chimneys on account of their greater structural mass. Chimneys that have a flue diameter larger than the stove outlet take more heat to warm, thus resulting in a faster cooling of the hot gases needed to build or maintain draft.

### 4. Chimney Installation and Maintenance

Confirm that **all four minimum chimney height requirements** listed in the Chimney Connection section of the manual have been met. The physics that link chimney height with draft creation are vital to the proper operation of the stove. Failure to meet each of these minimum requirements will have an adverse affect on draft. Avoid long horizontal runs or multiple elbows. Use stove cement to seal joints in the connector pipe section. Regularly clean the chimney, connector pipe, rain cap, and spark arrestor screen. Creosote build up can reduce the chimney draw and possibly create a chimney fire.

### 5. Temporarily out of Operation

After the fire has burned out, open the air control to its fully open position. This will allow warm room air to enter the chimney and keep it as warm as possible until the stove is used again.

## SERVICE HINTS continued . . .

For assistance involving chimney draft issues, contact a knowledgeable licensed heating and cooling contractor in your area. For questions regarding manufactured chimney, contact the manufacturer of the chimney.

**NOTE: A DRAFT READING OF 0.05 TO 0.06 W.C. (WATER COLUMN) IS REQUIRED FOR PROPER BURNING OF THIS STOVE.**

### GLASS CARE

The following usage and safety tips should be observed:

1. Inspect the glass regularly for cracks and breaks. If you detect a crack or break, extinguish the fire immediately and contact the manufacturer for a replacement.
2. Do not slam the door or otherwise impact the glass. When closing doors, make sure that logs or other objects do not protrude to impact the glass.
3. Do not build fires against (or that might fall against) the glass.
4. Do not clean the glass with materials that may scratch (or otherwise damage) the glass. Scratches on the glass can develop into cracks or breaks during operation.
5. Never attempt to clean the glass while the unit is hot. If deposits are not very heavy, normal glass cleaners are adequate using a soft, non-abrasive cleaning pad. Heavier deposits may be removed with oven cleaners.
6. Never put substances which can ignite explosively in the unit. Even small explosions in confined areas can blow out the glass.

### GLASS REPLACEMENT

**CAUTION: REPLACE GLASS ONLY WITH 5MM HIGHTEMPERATURE CERAMIC GLASS OF THE PROPER SIZE. DO NOT USE TEMPERED GLASS OR DOUBLE THICKNESS WINDOW GLASS!**

Gasket and Glass cleaning products are available at local retail home centers. Manufacturers of cleaning products include, A.W. Perkins Co. ([www.awperkins.com](http://www.awperkins.com)) or Rutland Products ([www.rutland.com](http://www.rutland.com)).

After extensive use, the gasket material which provides glass and door seal may lose it's resiliency and will need to be replaced. Inspect glass and door gaskets periodically to ensure proper seal; if gaskets become frayed or worn, replace immediately.

### GLASS REPLACEMENT PROCEDURE:

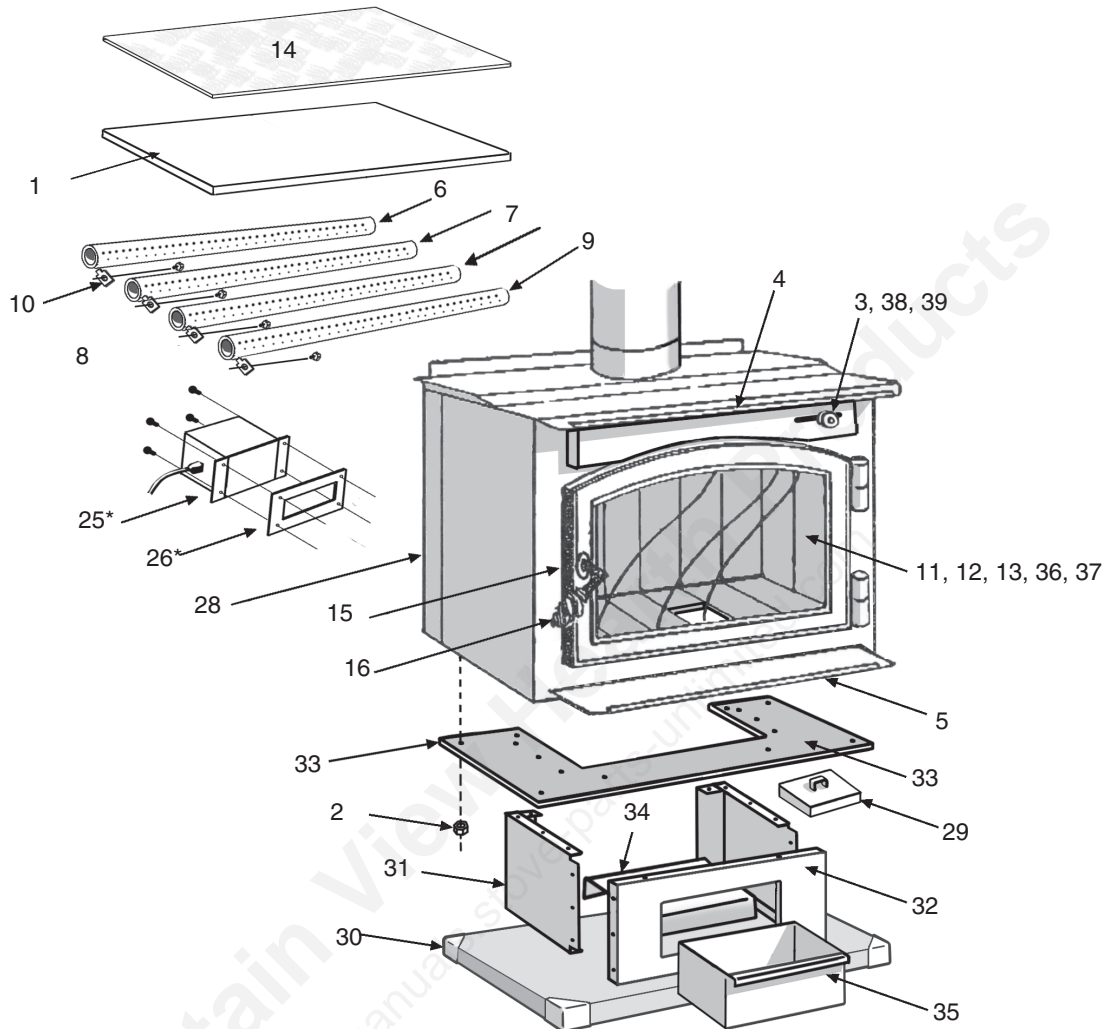
1. Ensure appliance is not in operation and is thoroughly cooled.
2. Remove screw and glass clip. (See parts list and diagram.)
3. Lift glass out from glass clip.
4. Remove old gasket and clean glass.
5. Replace new gasket starting at the bottom of glass working along edges, being sure to center gasket channel on glass.
6. Trim to length and butt ends together.
7. Replace glass into door, being sure not to over-tighten screw and clip.

### DOOR GASKET REPLACEMENT PROCEDURE:

1. Ensure appliance is not in operation and is thoroughly cooled.
2. Remove old door gasket and clean channel.
3. Using an approved, high temperature gasket cement, apply a thin coat in bottom of channel.
4. Starting at hinge side of door, work gasket into channel around door unit, end butt and trim to length.
5. Close door and allow three to four hours for cement to set before firing appliance.

# ORDERING PARTS - TR009 PERFORMER™ STOVE

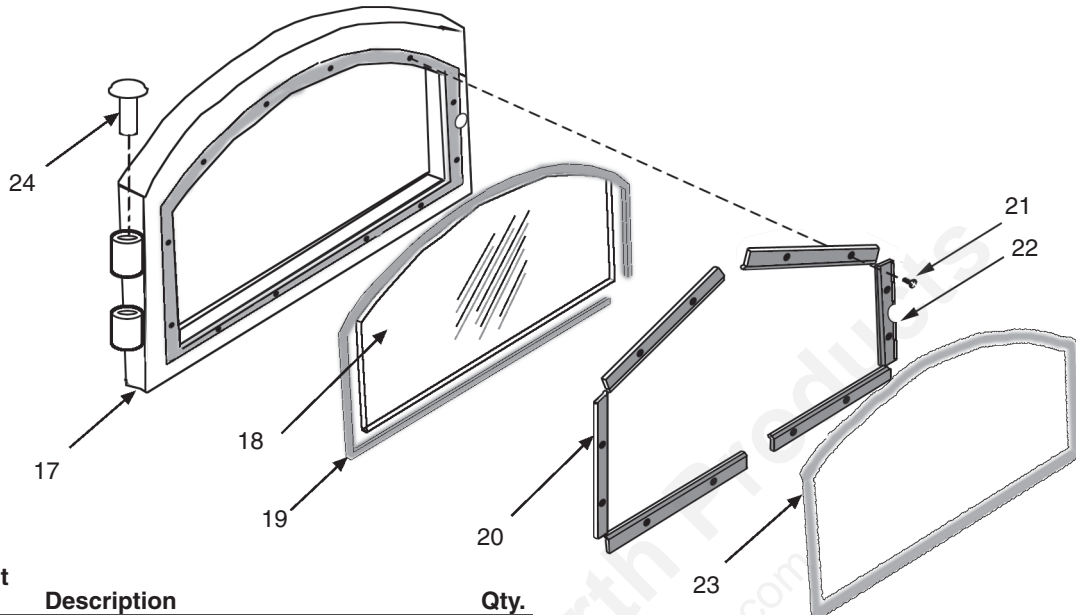
When ordering missing or replacement parts, always give the **Model Number** of the stove, **Part Number**, and **Part Description**. Use the illustrations and part lists provided to identify parts. Contact us at **616-396-1911** to order parts.



Ref. No.	Part No.	Description	Qty.	Ref. No.	Part No.	Description	Qty.
1	09-01	C-Cast Fiberboard.....	2	21	09-16	Screws, Glass Retainer.....	8
2	HP-09	Nuts (pedestal/stove attachment).....	4	22	09-17	Retainer, Glass, Handle Side.....	1
3	09-02	Handle, Slide Draft Spring.....	1	23	GK34	Gasket, Door.....	1
4	09-03	Nickle Trim, Top Plate.....	1	24	09-18	Hinge Pin.....	2
5	09-04	Nickle Trim, Hearth.....	1	25	F-6	Blower Assembly.....	1
6	09-05	Air Tube, Rear.....	1	26	09-19	Ceramic Gasket, Blower.....	1
7	09-06	Air Tube, Middle Rear.....	1	28	09-20	Rear Heat Deflector Assembly.....	1
8	09-07	Air Tube, Middle Front.....	1	29	09-21	Ash Clean out Cover.....	1
9	09-08	Air Tube, Front.....	1	30	09-22	Pedestal Base.....	1
10	09-009	Retainer Clips, Air Tube.....	4	31	09-23	Pedestal Side.....	2
11	A	Firebrick, A-size (9" x 4.5" x 1.25").....	16	32	09-24	Pedestal Front.....	1
12	M	Firebrick, M-size (9" x 2.25" x 1.25").....	1	33	09-25	Pedestal Top.....	1
13	N	Firebrick, N-size (4.5" x 4.5" x 1.25").....	1	34	09-26	Pedestal Drawer Support.....	1
14	09-10	Ceramic Fiber Pad.....	1	35	09-27	Ash Drawer.....	1
15	09-11	<b>Door Assembly (complete)</b> .....	1	36	O	Firebrick, O-size(6.75"x4.5"x1.25").....	1
16	09-12	Handle Assembly (complete).....	1	37	P	Firebrick, P-size(9"x4.5"x1.25"with notch).....	2
17	09-13	Door Frame.....	1	38	09-38	Slide Draft.....	1
18	09-14	Door Glass.....	1	39	09-39	Cover, Slide Draft.....	1
19	WG-01	Gasket, 7/8" Fiberglass Glass.....	1		HP-09	Hardware Pack (not shown).....	1
20	09-15	Retainer, Glass.....	5				

# PARTS - TR009 PERFORMER™ STOVE

When ordering missing or replacement parts, always give the **Model Number** of the stove, **Part Number**, and **Part Description**. Use the illustrations and part lists provided to identify parts. Contact us at **616-396-1911** to order parts.

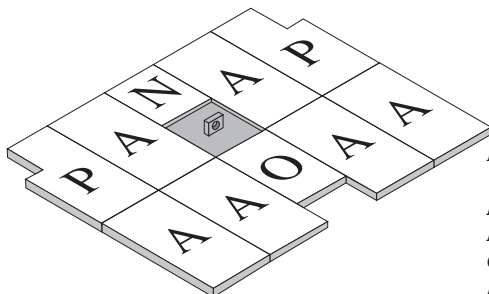
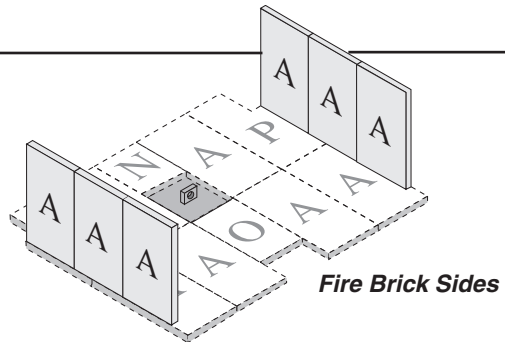


Ref. No.	Part No.	Description	Qty.
15	09-11	<b>Door Assembly (complete)</b> .....	1
16	09-12	Handle Assembly (complete) .....	1
17	09-13	Door Frame .....	1
18	09-14	Door Glass .....	1
19	WG-01	Gasket, 7/8" Fiberglass Glass .....	1
20	09-15	Retainer, Glass.....	5
21	09-16	Screws, Glass Retainer.....	8
22	09-17	Retainer, Glass, Handle Side .....	1
23	GK34	Gasket, Door .....	1
24	09-18	Hinge Pin.....	2

## FIREBRICK ASSEMBLY

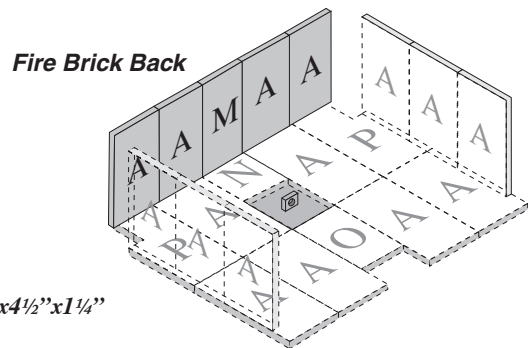
Ref. No.	Part No.	Description	Qty.
11	A	Fire Brick, A-size .....	16
12	M	Fire Brick, M-size.....	1
13	N	Fire Brick, N-size .....	1
36	O	Fire Brick, O-size.....	1
37	P	Fire Brick, P-size .....	2

**CAUTION: NEVER OPERATE STOVE WITH MISSING OR CRACKED FIRE BRICKS!**



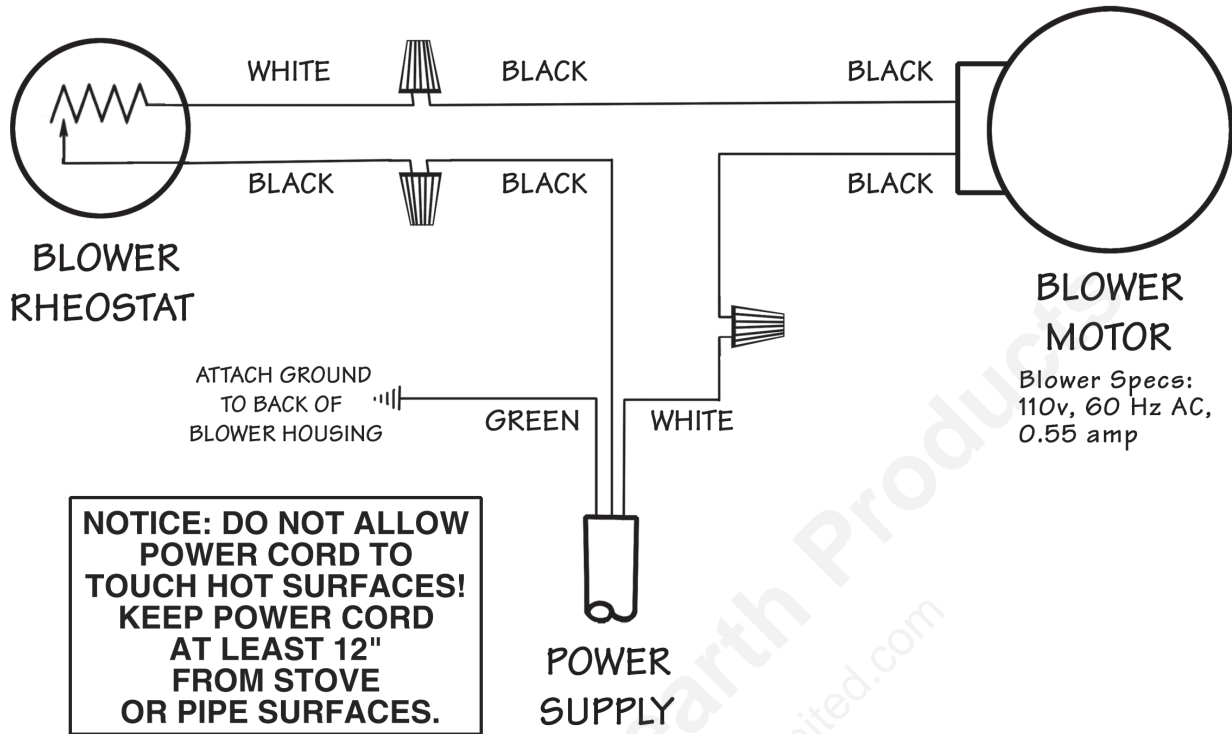
**Fire Brick Bottom**

**Fire Brick Dimensions**  
 A-size: 9"x4½"x1¼"  
 M-size: 9"x2¼"x1¼"  
 N-size: 4½"x4½"x1¼"  
 O-size: 6¾"x4½"x1¼"  
 P-size: 6"x1½"x3"x3"x9"x4½"x1¼"



**Fire Brick Back**

# WIRING DIAGRAM - MODEL F-6 BLOWER OPTION



# FLOOR PROTECTOR MATERIAL CALCULATIONS

This stove has been tested for and must be installed on a floor protector with the proper Thermal Resistance or R-value as stated in the installation instructions on page 7, "Locating Stove" step 1, of this manual. If the floor protector materials listed in the instructions are not available, materials with an equivalent R-value may be substituted.

Alternate materials may be rated with C-factor (Thermal Conductance) or k-factor (Thermal Conductivity) ratings which must be converted to R-value to determine if the alternate material meets the tested requirements. The following instructions provide the proper information and formulas for conversion to R-value.

To determine if alternate materials are acceptable follow this sequence.

1. Convert material specifications to R-value:
  - a. R-value given — no conversion necessary
  - b. K-factor is given with a required thickness (T) in inches:  

$$R = 1/k \times T$$
  - c. C-factor is given:  $R = 1/C$
2. Determine the R-value of proposed alternate floor protector:
  - a. Use formulas in step 1 above to calculate R-value of proposed material(s).
  - b. For multiple layers, add R-values of each layer to determine overall R-value.
3. If the overall R-value of the floor protector system is equal to or greater than the floor protector specifications given, the alternate is acceptable.

Definitions:

$$\text{Thermal conductance}(C) = \frac{\text{BTU}}{(\text{hr})(\text{ft}^2)(\text{°F})} = \frac{\text{W}}{(\text{m}^2)(\text{°K})}$$

$$\text{Thermal conductivity}(k) = \frac{(\text{Btu})(\text{inch})}{(\text{hr})(\text{ft}^2)(\text{°F})} = \frac{\text{W}}{(\text{m})(\text{°K})} = \frac{\text{Btu}}{(\text{hr})(\text{ft})(\text{°F})}$$

$$\text{Thermal resistance}(R) = \frac{(\text{ft}^2)(\text{hr})(\text{°F})}{\text{Btu}} = \frac{(\text{m}^2)(\text{°K})}{\text{W}}$$

Example:

The specs of floor protector material should be 3/4-inch thick material with a k-factor of 0.84. The proposed alternative material is 4" brick with a C-factor of 1.25 over 1/8-inch mineral board with a k-factor of 0.29.

Step 1: Convert specs to R-value.

$$R = 1/k \times T = 1/0.84 \times 0.75 = 0.893 \quad \text{System must have a R-value of } 0.893 = R_{\text{specs}}$$

Step 2: Calculate R-value of individual components

$$4" \text{ Brick with C-factor} = 1.25. \quad R = 1/C = 1/1.25 = 0.80 = R_{\text{brick}}$$

$$1/8\text{-inch (0.125") mineral board with k-factor} = 0.29. \quad R = 1/0.29 \times 0.125 = 0.431 = R_{\text{min.brd.}}$$

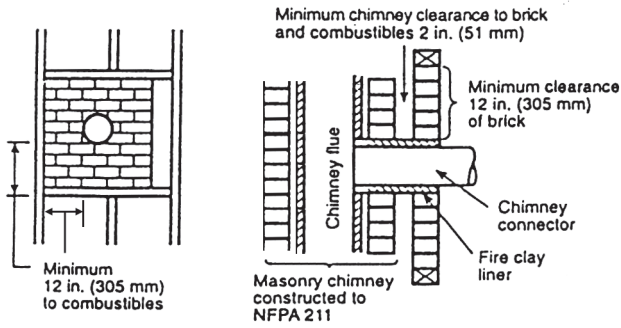
Step 3: Add R-values of components to get total R-value of system

$$R_{\text{brick}} + R_{\text{min.brd}} = 0.80 + 0.431 = 1.231 = R_{\text{system}}$$

Step 4: Compare R<sub>system</sub> to R<sub>specs</sub>

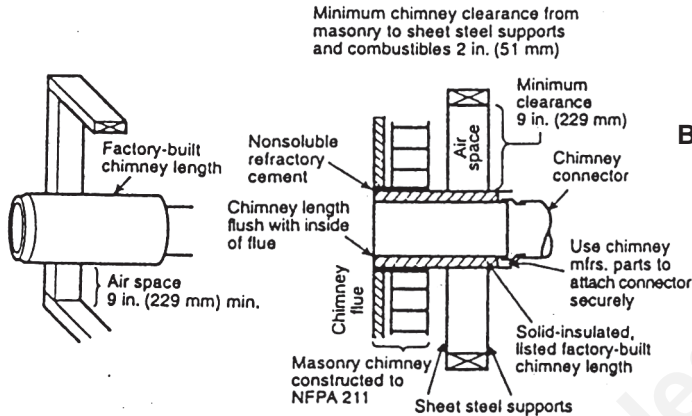
R<sub>system</sub> = 1.231 is larger than R<sub>specs</sub> of 0.893. System R-value exceeds the required specifications and therefore is an acceptable alternative.

# CHIMNEY CONNECTOR SYSTEMS & CLEARANCES



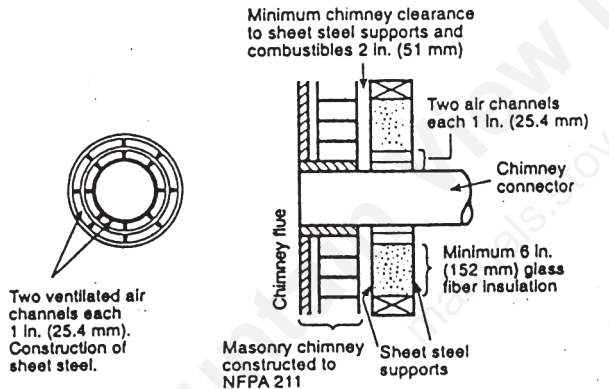
## A. Brick Masonry

Minimum 3.5"/89mm thick brick masonry all framed into combustible wall with a minimum of 12"/305mm brick separation from clay liner to combustibles. The fireclay liner shall run from outer surface of brick wall to, but not beyond, the inner surface of chimney flue liner and shall be firmly cemented in place.



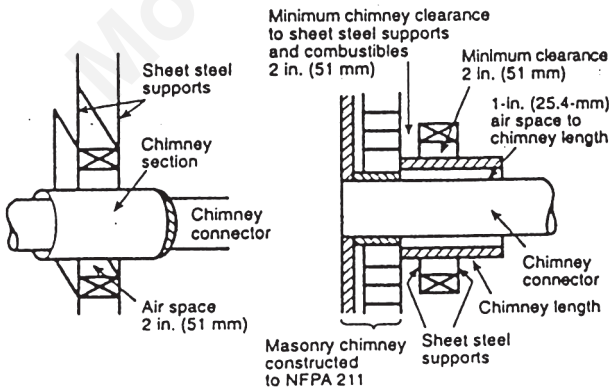
## B. Insulated Sleeve

Solid-insulated, listed factory-built chimney length of the same inside diameter as the chimney connector and having 1"/25.4cm or more of insulation with a minimum 9"/229mm air space between the outer wall of the chimney length and combustibles.



## C. Ventilated Thimble

Sheet steel chimney connector, minimum 24 gauge in thickness, with a ventilated thimble, minimum 24 gauge in thickness, having two 1"/25.4mm air channels, separated from combustibles by a minimum of 6"/152mm of glass fiber insulation. Opening shall be covered, and thimble supported with a sheet steel support, minimum 24 gauge in thickness.



## D. Chimney Section Pass-through

Solid insulated, listed factory-built chimney length with an inside diameter 2"/51mm larger than the chimney connector and having 1"/25.4mm or more of insulation, serving as a pass-through for a single wall sheet steel chimney connector of minimum 24 gauge thickness, with a minimum 2"/51mm air space between the outer wall of chimney section and combustibles. Minimum length of chimney section shall be 12"/305mm chimney section spaced 1"/25.4mm away from connector using sheet steel support plates on both ends of chimney section. Opening shall be covered, and chimney section supported on both sides with sheet steel support securely fastened to wall surfaces of minimum 24 gauge thickness. Fasteners used to secure chimney section shall not penetrate chimney flue liner.

---

Mountain View Hearth Products  
manuals.stove-parts-unlimited.com

---

This Vogelzang heating appliance is safe when installed properly and will provide you with years of service. However, always exercise good judgement when you are using this stove. You are dealing with FIRE! Fire is inherently dangerous and must be treated with respect. Stay warm and in good health!

Respectfully yours,  
*Steve Vogelzang*  
Proprietor

**DO NOT USE THIS STOVE IN A  
MOBILE HOME, MANUFACTURED HOME,  
TRAILER OR TENT — NO EXCEPTIONS!**

**COMPANY TESTIMONY:**

**“FOR GOD SO LOVED THE WORLD THAT HE GAVE HIS ONLY BEGOTTEN SON, THAT WHOEVER BELIEVES IN HIM SHALL NOT PERISH BUT HAVE ETERNAL LIFE”**

**JOHN 3:16**

**MADE IN CHINA**

**VOGELZANG**

*International* CORPORATION



*Vogelzang International Corporation*

*400 West 17th Street*

*Holland, Michigan 49423*

*www.vogelzang.com*

*Phone: 1-616-396-1911*

*Fax: 1-616-396-1971*