

**INSTRUCTION AND PARTS BOOK  
FOR  
MODELS 526, 2900, & 4000**

Installation must be made in accordance with local and state codes which may differ from manual. *Save these instructions.*

# **WOODCHUCK**

## **WOOD/COAL FURNACES**

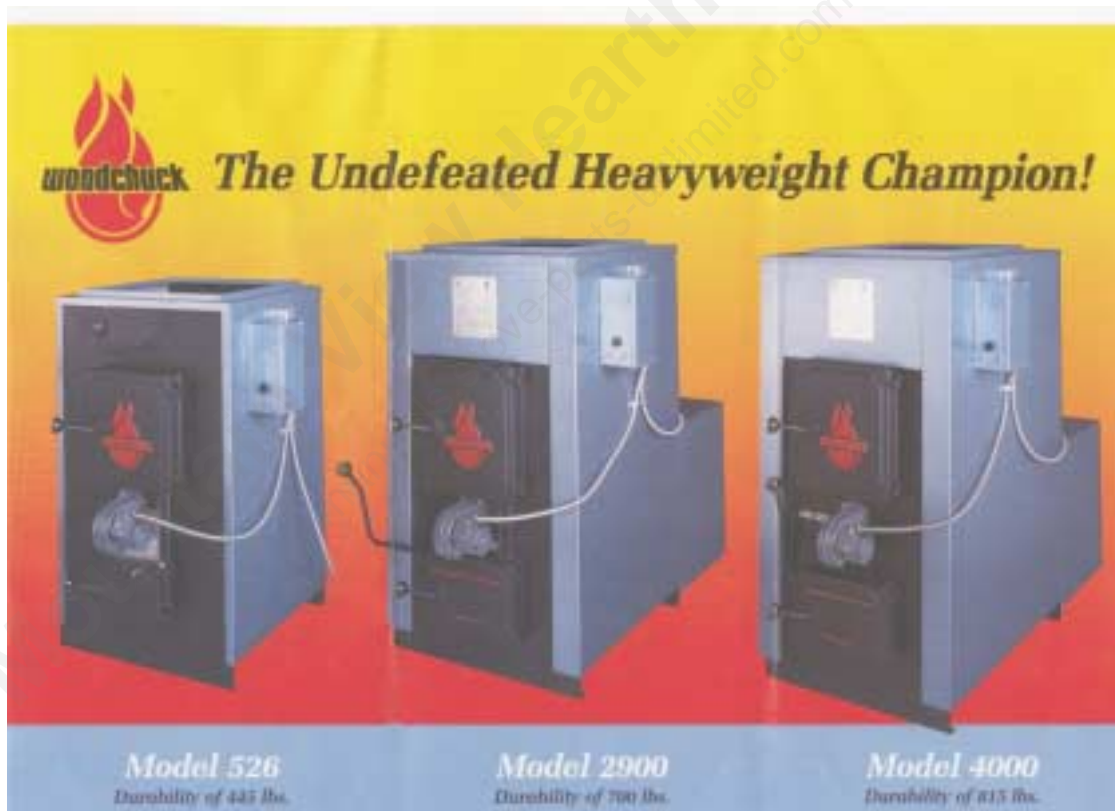

**Manufactured by**  
**Meyer Mfg. Corp.**

Phone 715/654-5132  
Fax 715/654-5513

07/97

**Dorchester, Wisconsin 54425**

# INTRODUCTION

Dear Woodchuck Owner,

Congratulations on your purchase of a Woodchuck heating appliance. Undoubtedly you have given much consideration to your purchase and we're proud that you have selected a Woodchuck. Pride in craftsmanship and engineering have made your Woodchuck the finest heating appliance available today.

Solid fuels are abundant and inexpensive. Wood is our only renewable source of fuel and conservative estimates put our coal reserves at 800 years. Our dual fuel units provide the savings and comfort of solid fuels and the convenience of electric heat in one attractive package.

There is no substitute for quality. That is why thousands of people like you have purchased a Woodchuck. They also felt it was the best equipment to serve their heating needs, now and in years to come. We ask that you follow our policy of "safety first" and we strongly suggest that you read through the owner's manual before installing and operating your furnace.

For a lifetime of satisfaction, thank you for not compromising with quality.

Sincerely,

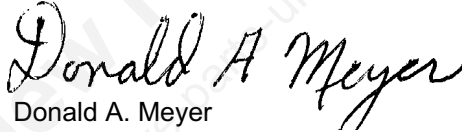

Donald A. Meyer  
President  
MEYER MANUFACTURING CORP.



We are constantly improving and updating our product in order to provide the highest quality and value possible. Consequently pictures might sometimes differ slightly from the actual product.

## TRANSPORTATION DAMAGES

Before reading this manual and proceeding with the installation, inspect your new Woodchuck to make sure there were no shipping damages. If you find there have been damages incurred, call your dealer immediately. He will then take a course of action to correct the problem.

# TABLE OF CONTENTS

	Page
Introduction.....	2
Table of Contents.....	3
Furnace Safety.....	4
Specifications.....	5
General Information.....	6
High Quality Construction.....	6
Efficiency.....	6
Comfort.....	6
Additional Comfort And Saving.....	7
Operation.....	8
Common Sense.....	8
! If You Have Chimney Fire !.....	8
! Important ! Operation Procedure In The Event of Power Failure.....	8
Operating Your Woodchuck Furnace.....	9
Startup.....	9
Burning Wood In Your Woodchuck.....	9
Helpful Hints.....	10
Ash Removal.....	10
Burning Coal In Your Woodchuck.....	11
Starting A Coal Fire.....	11
Recharging.....	11
Banking.....	11
Bituminous Recharging.....	11
Helpful Hints.....	11
Ash Removal.....	12
Maintenance.....	12
Trouble Shooting.....	13
Installation.....	15
General Requirements.....	15
Placement And Minimum Clearances.....	15
Chimney Installation.....	17
Installing Your Woodchuck.....	18
Stove Pipe Installation.....	18
Installation Of A Barometric Draft.....	18
Air Duct Installation.....	19
Woodchuck Final Assembly.....	20
Optional Shaker Grate Installation-Model 526.....	20
Install Shaker Grate Handle, Model 2900 Only.....	21
Install Firebrick.....	22
Install Optional Catalytic Combustor.....	22
Assemble Manual Draft-Model 526 Only.....	23
Install Comfort Control Center And Forced Draft Blower.....	23
Install Circulating Blower.....	24
Assemble Filter Box.....	24
Electrical Hookup.....	25
Repair Parts.....	27

# FURNACE SAFETY

THERE ARE INHERENT HAZARDS ASSOCIATED WITH THE OPERATION OF WOOD/COAL FURNACES. FOR YOUR SAFETY READ, UNDERSTAND, AND HEED THE FOLLOWING:

## DANGER:

RISK OF FIRE OR EXPLOSION. DO NOT BURN GARBAGE, GASOLINE, DRAIN OIL, OR OTHER FLAMMABLE LIQUIDS. FAILURE TO HEED MAY RESULT IN SERIOUS PERSONAL INJURY OR DEATH.

## DANGER:

NEVER USE CHEMICALS OR FLUIDS SUCH AS GASOLINE, CHARCOAL LIGHTER FLUID, DRAIN OIL, FUEL OIL OR KEROSENE TO LIGHT A FIRE IN YOUR WOODCHUCK. FAILURE TO HEED MAY RESULT IN SERIOUS PERSONAL INJURY OR DEATH.

## DANGER:

DURING OPERATION, LOADING AND ASH DOORS, AND EXPOSED FIREBOX ARE EXTREMELY HOT. NEVER TOUCH THESE PARTS WHEN HOT. FAILURE TO HEED MAY RESULT IN SERIOUS PERSONAL INJURY.

## CAUTION:

Risk Of Fire

Do Not Operate With Fuel Loading Or Ash Removal Doors Open.

Do Not Store Fuel Or Other Combustible Material Within Marked Installation Clearances.

Under Certain Conditions Of Use, Creosote Buildup May Occur Rapidly. Inspect And Clean Flues And Chimney Regularly.

Wait 10 Seconds On First Latch Before Refueling. Opening Loading Door Rapidly Can Cause A Flame To Flash Out The Door. Use Caution When Opening Loading Door.

Unsafe To Load Coal Above Top Of Brick.

Keep Ash Pan Out Of Unit During Operation. Ash Pan Can Get Very Hot.

Ash Can Must Be Placed On A Noncombustible Surface.

Never Use Anything But An Air Tight Metal Container To Dump Your Ashes In. Every Year Many Fires Are Caused By Emptying Ashes Into Cardboard Boxes Or Paper Bags.

Proven Fact - Small Red Embers Buried In Ash Cans Stay Red Hot For Days. Ashes Are A Good Thermal Insulator And Keep Enough Oxygen Away So Embers Do Not Burn Out.

THERE ARE ADDITIONAL HAZARDS ASSOCIATED WITH IMPROPER INSTALLATION OF WOOD/COAL FURNACES AND WITH SERVICE AND MAINTENANCE OF WOOD/COAL FURNACES. FOR YOUR SAFETY READ, UNDERSTAND, AND HEED THE FOLLOWING:

## WARNING:

DISCONNECT APPLIANCE FROM ELECTRICAL SUPPLY BEFORE SERVICING UNIT. FAILURE TO HEED MAY RESULT IN SERIOUS PERSONAL INJURY OR DEATH.

## CAUTION:

Equipment Must Be Installed By A Qualified Heating Person.

Only "class A" All-fuel Or Solid Fuel Chimneys Intended For Use With Your Woodchuck Should Be Used.

Furnace Must Be Installed On A Noncombustible Floor Or 3/8" Thick Fireproof Millboard Or Equivalent.

**FAILURE TO HEED MAY RESULT IN SERIOUS PERSONAL INJURY OR DEATH.**

# SPECIFICATIONS

## MODEL 526

Height	42.5"
Width	24"
Depth	26"
Blower	850 to 1850 CFM
Max. BTU Capacity	120,000
Log Size	22"
Loading Door Size	14"x12"
Weight, Approx.	445 lbs.
Warm Air Plenum	20"x23"
Flue Outlet	6" Dia.
Flue Collar Height	41" Overall Height
Secondary Heat Exchange	YES
Listings	UL391, CSA B366, 1-M ETLM
Firebox Chamber	6.10 cu. ft.

## MODEL 2900

Height	48.5"
Width	26"
Depth	28"
Blower	850 to 1850 CFM
Max. BTU Capacity	150,000
Log Size	22"
Loading Door Size	15"x13"
Weight, Approx.	700 lbs.
Warm Air Plenum	20"x23"
Flue Outlet	8" Dia.
Flue Collar Height	47" Overall Height
Secondary Heat Exchange	YES
Listings	UL391, CSA B366, 1-M ETLM
Firebox Chamber	7.70 cu. ft.

## MODEL 4000

Height	51.5"
Width	26"
Depth	33"
Blower	850 to 1850 CFM
Max. BTU Capacity	180,000
Log Size	24"
Loading Door Size	15"x13"
Weight, Approx.	815 lbs.
Warm Air Plenum	20"x23"
Flue Outlet	8" Dia.
Flue Collar Height	50" Overall Height
Secondary Heat Exchange	YES
Listings	UL391, CSA B366, 1-M ETLM
Firebox Chamber	9.10 cu. ft.

## DISCLAIMER NOTICE

The heating capacity specifications are provided as guidelines only and in no way guarantee the output or capacity of the units. The actual BTU output depends on the type of fuel being burned and its condition, the thermostat setting, the draft adjustments and the chimney that the unit is installed into.

# GENERAL INFORMATION

Woodchuck furnaces represent the ultimate in solid fuel and dual fuel heating appliances. From the massive model 4000 to the economy model 526, each unit is designed to be attractive, durable and efficient while providing the safety and comfort you and your family deserve.

## HIGH QUALITY CONSTRUCTION

Constructed of high grade, heavy gauge, hot rolled steel plate, the firebox is continuously welded for an airtight seal and structural strength. The heavy duty cast iron doors are equipped with a positive latching device for your safety. The loading door has a two-step safety latch. The large cast iron grates provide for durability and help promote efficient combustion of the fuel. The firebox is lined with heavy duty firebrick and is done so without any retainers to warp or burn out. These features together with high quality electrical components provide the safety, efficiency and total control possible only in a Woodchuck. Total control means that you can better avoid overheating the unit and developing excessive and unsafe temperatures.

Woodchuck furnaces are subjected to the most stringent test criteria applicable by an independent third party testing laboratory and listed/labeled as having met or exceeded those standards. Finally, any machine, even this Woodchuck, is only as safe as the person operating it. This is why we have compiled this comprehensive manual to assist you in operating your Woodchuck properly and safely. Please read and follow all instructions.

## EFFICIENCY

The total efficiency of a unit is broken down into combustion efficiency and transfer efficiency. We know that when woodburning, 20% of it burns as fixed carbon. The other 80% is in the gaseous state as it burns. Therefore, to obtain efficient combustion of the wood it is necessary to introduce 20% of the oxygen "under" the fire to promote combustion of the solid material and 80% "over" the fire where it can readily react with the gaseous material. Coal burns just the opposite of wood. 80% of it burns as fixed carbon and 20% burns in the gaseous state. Therefore, before a furnace can burn coal or wood efficiently, it must provide the 80/20 ratio of combustion air and allow the operator to reverse the ratio depending on the fuel being used. Combustion air must be warm when it enters the firebox to further promote complete combustion. Your Woodchuck furnace provides all these features and more. Here is how: when combustion air enters a Woodchuck furnace it enters into a "draft

channel." Here it comes into contact with the hot firebox front and is warmed before entering the firebox. The draft channel is equipped with adjustable orifices which provide for the 80/20 distribution of the combustion air. A lever on the front of Models 2900/4000 allows for quick and easy adjustment of these orifices to correspond to the fuel being used. As the air enters the firebox it strikes a deflector which creates a turbulence and causes the oxygen to mix thoroughly with the gases for complete combustion.

Finally, Woodchuck Model 2900/4000 furnaces are designed to accept a catalytic combustor. This device will cause the small amount of unburned fuel to ignite before entering the secondary heat exchanger. The benefits of all this are threefold:

- A.) You obtain very high combustion efficiencies, meaning you use less fuel.
- B.) You reduce the amount of unburned fuel that can collect in your chimney as creosote and hence reduce the hazard of a chimney fire.
- C.) You virtually eliminate pollution of the air we all breathe.

Transfer efficiency refers to how effectively we transfer the heat generated inside the firebox to the rooms we want to heat. Insufficient blower capacity will result in poor transfer allowing the unused heat to escape up the chimney. This is why we utilize a blower with such large air handling capacity. The large surface area of the firebox and secondary heat exchanger provide for efficient transfer.

## COMFORT

Comfort and efficiency are closely related. The more efficient the heating system is, the more comfortable you and your family are. Not only are the Woodchuck furnaces efficient, they can actually increase the efficiency of your home.

On a furnace with a conventional single speed blower, the speed of the blower is a compromise between comfort and efficiency. If the blower has a large enough capacity to heat the home in the coldest weather it will cycle rapidly in milder weather so the system air is not as warm. If this air is moved too rapidly it can actually feel cool. Air that is moving at 3 ft. per second will feel 4° cooler than stationary air at the same temperature. If the blower capacity is enough to operate properly in mild

weather, it will not be large enough to keep the house

warm in cold weather. This could cause the furnace to overheat and a loss of heat up the chimney. The result then is a compromise which is neither efficient or comfortable. Woodchuck furnaces, however, have a three speed circulation blower which can be adjusted via a three position rotary switch on the Comfort Control Center. This allows the user to select the blower speed to meet the air movement requirements of the installation. In addition, when the weather is mild and the furnace is operating at a lower output, the blower can be set on low to gently move the air. Similarly, when it is cold and the furnace is operated at higher levels of heat, output can be switched to higher speeds.

But how can all this improve the efficiency of your home? As figure 1 illustrates, heated air rises away from the living area and stratifies. This causes large temperature differentials between the ceiling where heat is lost rapidly through conduction and the floor where children often play. By allowing for continuous air movement, even during periods of low heat output, this stratification is not allowed to take place. You are

more comfortable and lose less heat through your ceilings as illustrated in figure 2.

This situation can be especially troublesome in multi-level homes as illustrated in figure 3. As soon as the blower shuts off, the air in the home begins to stratify; warm air rising to the upper levels and cool air collecting in the lower levels. The lower levels become increasingly uncomfortable until the blower turns on again. Unfortunately, the upper levels are still warm so they become uncomfortably warm before the blower turns off. By allowing for a steadier, more continuous operation of the blower the entire house stays at a more constant and comfortable level, figure 4.

### ADDITION COMFORT AND SAVING

Options are available for your Woodchuck furnace, and one of these deserve special mention. The Aqua-Siphon is capable of pre-heating your domestic water free of charge during the heating season for additional saving to you.

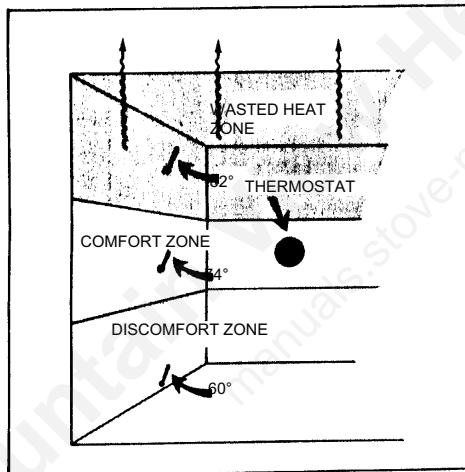

FIGURE 1

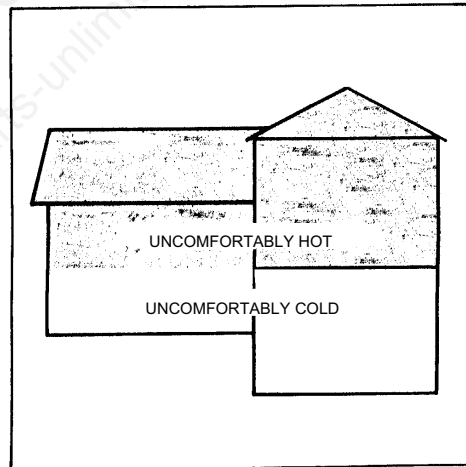

FIGURE 3

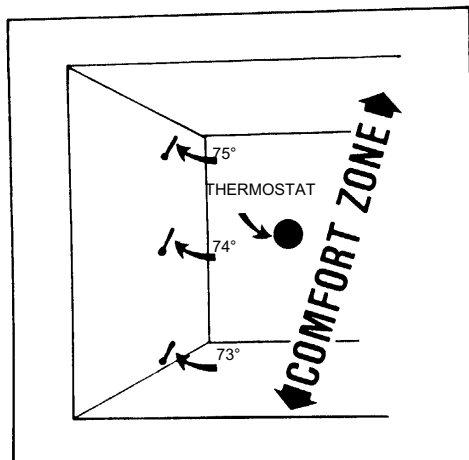

FIGURE 2

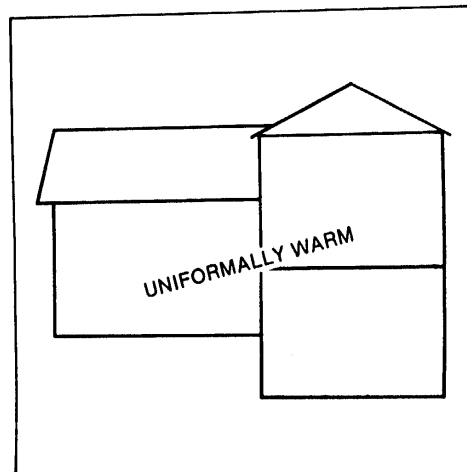

FIGURE 4

# OPERATION

## COMMON SENSE

Please read the following before firing your furnace. It is most important that you follow these suggestions and limitations in order to maintain your warranty and guarantee the long life of your furnace.

**NOTE:** Smoke detectors and fire extinguishers should always be a part of your equipment.

This furnace is an airtight unit designed to burn 6-8 hours per load of wood or coal. If the furnace is being fired hot constantly with full flames and operating at only 2-4 hour burn cycles, it may be over fired. Your home heating needs may be too great for the size of furnace you have purchased. Your furnace can be damaged if fired at extremely high temperatures.

Forced firing or abuse can be detected upon inspection AND WILL VOID YOUR WARRANTY.

### **DANGER:**

RISK OF FIRE OR EXPLOSION. DO NOT BURN GARBAGE, GASOLINE, DRAIN OIL, OR OTHER FLAMMABLE LIQUIDS. FAILURE TO HEED MAY RESULT IN SERIOUS PERSONAL INJURY OR DEATH.

### **DANGER:**

NEVER USE CHEMICALS OR FLUIDS SUCH AS GASOLINE, CHARCOAL LIGHTER FLUID, DRAIN OIL, FUEL OIL OR KEROSENE TO LIGHT A FIRE IN YOUR WOODCHUCK. FAILURE TO HEED MAY RESULT IN SERIOUS PERSONAL INJURY OR DEATH.

### **CAUTION:**

RISK OF FIRE  
DO NOT OPERATE WITH FUEL LOADING OR ASH REMOVAL DOORS OPEN.  
DO NOT STORE FUEL OR OTHER COMBUSTIBLE MATERIAL WITHIN MARKED INSTALLATION CLEARANCES.  
INSPECT AND CLEAN FLUES AND CHIMNEY REGULARLY.  
UNDER CERTAIN CONDITIONS OF USE, CREOSOTE BUILDUP MAY OCCUR RAPIDLY.  
WAIT 10 SEC. ON FIRST LATCH BEFORE REFUELING.  
LOAD FUEL CAREFULLY OR DAMAGE MAY RESULT.

## ! IF YOU HAVE CHIMNEY FIRE !

Meyer Mfg. Corp. recommends the following actions:

1. Shut any doors and air inlet dampers and draft control. This should take no longer than a few seconds.

CLOSED

2. Alert everyone in the house.

3. Call the fire department.

MANUAL DRAFT



**NOTE:** Emptying a large box of baking soda will slow down the fire in your Woodchuck.

Keeping your chimney and stove pipe clean is the best insurance against chimney fires.

## ! IMPORTANT ! OPERATION PROCEDURE IN THE EVENT OF POWER FAILURE:

Your Woodchuck can operate and produce heat without electric power. This is one of the features built into every Woodchuck.

The following steps should be taken in the event of an electrical power failure:

1. Locate all heating duct dampers (not smoke pipe damper), if any, to open position.

CLOSED

2. Turn manual draft controls to this position.

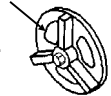

Ash door should never be used in power failure.

MANUAL DRAFT

3. Remove filter box service access cover, allowing cooler air to move hot air through the furnace, cooling the plenum and the house hot air duct system.

If power fails, to avoid product damage, close manual draft completely. Forced draft and natural draft are pre-set.

In the event of a runaway fire, close all drafts. Close smoke damper halfway.

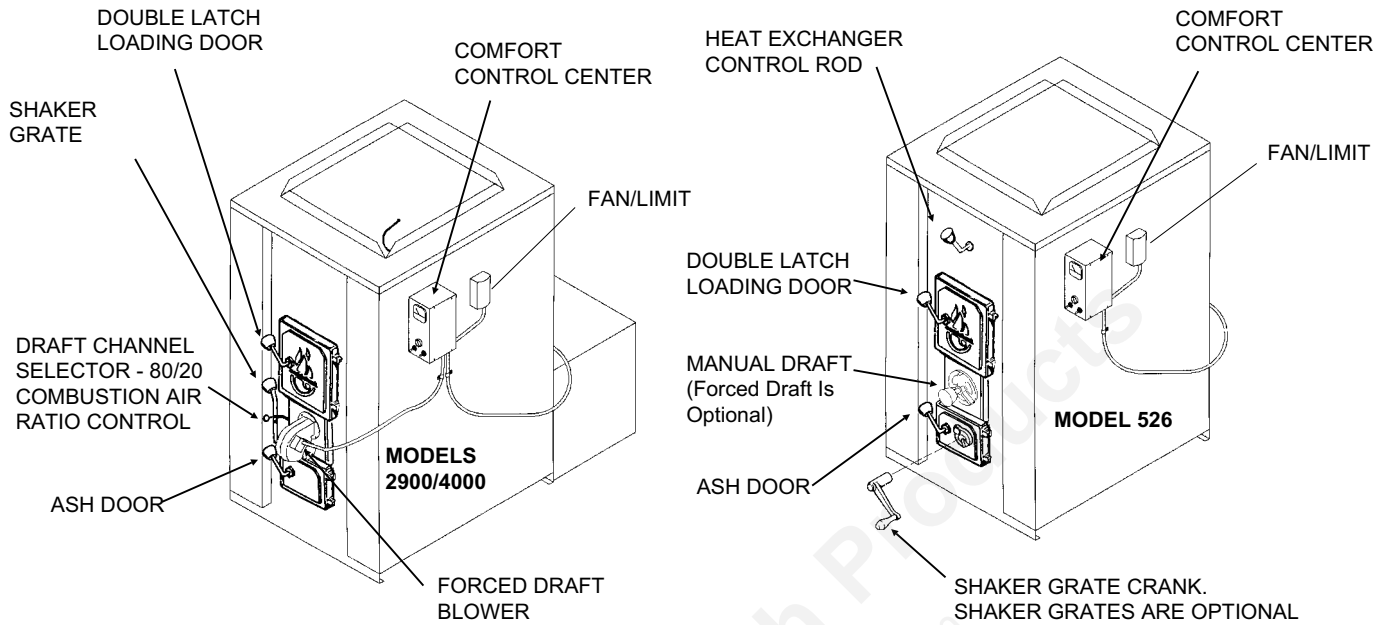

**FIGURE 5 WOODCHUCK CONTROLS**

**NOTE:** All models are equipped with a "low limit" which will not allow the auto draft to operate when the unit is not warm. To start auto draft, turn Lo-Limit toggle switch on comfort control center to "On", figure 6.

Now you are ready to light a fire.

## BURNING WOOD IN YOUR WOOD-CHUCK

1. Adjust draft channel selector, figure 5, to appropriate fuel setting on model 2900/4000. On Model 526 with manual draft, open it. Place several pieces of crumpled paper in the center of your Woodchuck. Criss-cross a couple of handfuls of dry kindling wood 3/4" thickness, then several small dry pieces of firewood. Ignite the paper and close the door. Do not attempt to open the door immediately after igniting the fire. There could be a flame flash out.

2. It will take 5-10 minutes for the fire to establish itself. Once you have some good red hot burning embers, add larger pieces of wood. All chimneys and hookups are different. After 3-4 fires, you'll find out how your unit works for the best starting.

3. After about 30-40 minutes you can adjust the draft according to your needs. Adjust smoke pipe damper according to your needs also.

**NOTE:** On airtight units, the burning time is controlled mostly by the draft controls on the furnace, contrary to

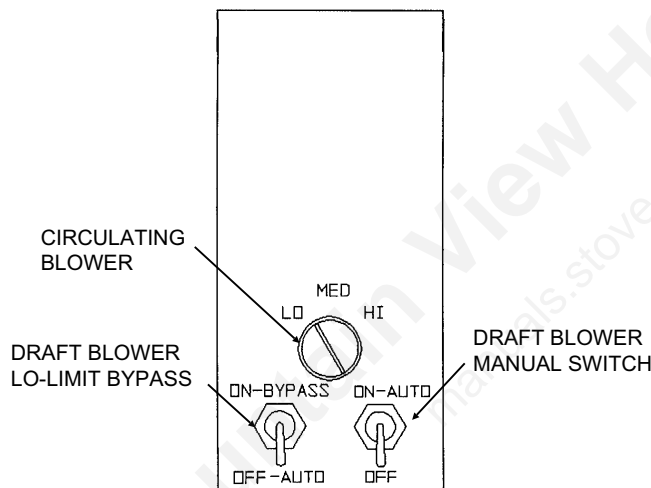

**FIGURE 6 COMFORT CONTROL CENTER**

## OPERATING YOUR WOODCHUCK FURNACE

### STARTUP

Never leave ash pan in unit. Use only when cleaning out ashes.

First thing is to check that your main blower and draft blower are in proper working order before lighting a fire. To check main blower, push button on fan/limit control for manual override testing. When finished, reset to automatic position, figure 5. Next, turn thermostat upstairs to high temperature so draft blower turns on.

the old type of pot belly stoves where the smoke pipe damper controlled the burning time.

**NOTE:** With new steel, there is a small amount of oil or dirt on the metal and you may smell an odor. Provide adequate ventilating to home during the first operation. Your new Woodchuck is capable of putting out many BTU's, so treat it with respect. Don't fully load your furnace or open all drafts fully until you have become thoroughly familiar with the operation of the furnace.

**NOTE:** A full load does not always give the best results for your needs.

4. When loading your Woodchuck with existing hot coals, rake red hot embers over grates evenly. Put a few small pieces of wood on the coals first, then load-up.

5. If you have the automatic draft control, turn low limit by-pass switch to "On". Turn thermostat up to activate auto draft and proceed as with manual draft. Once the unit is warmed up you can turn the low limit by-pass switch to "OFF". This will allow the auto draft to shut off if the unit runs out of fuel while you are gone.

### **CAUTION:**

WAIT 10 SECONDS ON FIRST LATCH BEFORE REFUELING. OPENING LOADING DOOR RAPIDLY CAN CAUSE A FLAME TO FLASH OUT THE DOOR. THIS OCCURS WHEN THERE IS UNBURNT FUEL AND A LARGE AMOUNT OF GASES ON TOP OF THE FIRE-BOX. WHEN THE DOOR IS OPEN, OXYGEN IS COMBINED WITH GASES AND IGNITES. USE CAUTION WHEN OPENING LOADING DOOR.

### **HELPFUL HINTS**

Adjust the draft to the proper setting for your home needs. The chimney, hookups, and kind of wood will also be a factor.

Your Woodchuck is capable of holding very large logs. DO NOT try to add a log that is larger than you can easily place in the furnace. You will get the best efficiency when you add only the amount of wood needed for a 6 to 8 hour burn.

In the spring and fall, the weather is mild, which will allow you to burn very large loads of wood for long periods of time and hence accumulate very large amounts of creosote. KEY: Stack temperature should be 300°F-400°F for good burning. An external flue temperature thermometer (Woodchuck part #08-0084) is included in the owner's manual package for monitoring stack temperature. Install the flue temperature ther-

mometer at the rear of the furnace on the smoke pipe where it connects to the collar on the back of the Woodchuck. 300-400 degrees should be maintained when the Woodchuck is operating in the burn cycle with the forced draft blower running to eliminate a creosote build up. (If the unit has a manual draft or a natural draft, monitor the flue temperature when the drafts are in the open position). Depending on the weather, you may not need a full load of wood for a good over night burn. You will get best efficiency when you add only the amount of wood needed until the next time you are available to load.

Always try to place the logs so air can flow between them -this will enhance combustion considerably.

### **ASH REMOVAL**

When burning wood, run your poker over top of the grate to be sure grate slots are clear of burnt fuel. This should be done every morning when there is just a bed of hot coals.

### **CAUTION**

NEVER LET ASHES BUILD-UP TO GRATE LEVEL. THIS WILL GREATLY REDUCE THE LIFE SPAN OF YOUR GRATE.

Wood ash is useful as a fertilizer, particularly because of its potassium content. Ashes will also decrease the acidity of garden soil.

### **CAUTION**

KEEP ASH PAN OUT OF UNIT DURING OPERATION. ASH PAN CAN GET VERY HOT. ASH CAN MUST BE PLACED ON A NONCOMBUSTIBLE SURFACE. NEVER USE ANYTHING BUT AN AIR TIGHT METAL CONTAINER TO DUMP YOUR ASHES IN. EVERY YEAR MANY FIRES ARE CAUSED BY EMPTYING ASHES INTO CARDBOARD BOXES OR PAPER BAGS. PROVEN FACT- SMALL RED EMBERS BURIED IN ASH CANS STAY RED HOT FOR DAYS. ASHES ARE A GOOD THERMAL INSULATOR AND KEEP ENOUGH OXYGEN AWAY SO THE EMBERS DO NOT BURN OUT.

## BURNING COAL IN YOUR WOOD-CHUCK

Never attempt to burn coal without a shaker grate. Shaker grates are standard on Models 2900 and 4000 but optional on Model 526.

A barometric draft control in the smoke pipe must be used when burning coal.

### CAUTION:

UNSAFE TO LOAD COAL ABOVE TOP OF FIRE BRICK.

## STARTING A COAL FIRE

Open all draft controls on your Woodchuck.

Build a fire using dry wood kindling and establish a bed of coals. Add several small shovels of coal over the wood coals. After the coal fire is established and spread throughout the firebox, add larger amounts of coal to build up the coal bed. Gently shake the grate until live coals fall into the ash pan area. Allow your Woodchuck to operate with drafts open for approximately 15 minutes or until fresh coal ignites. When the coal is properly ignited, adjust the drafts accordingly. Check the fire periodically to be sure it is spreading through the coal bed.

## RECHARGING

Gently shake grates down. Open drafts and establish a good flow of primary air below the grates. When recharging, fresh coal tends to give off large quantities of volatile gas. This gas may accumulate and possibly ignite causing a backpuff. To reduce back-puffing, open the fire door to the first safety latch position for 15-20 seconds before opening fully. Spread fresh coal evenly over existing coal, leaving some hot coals exposed in the center of the firebox. Be careful not to smother your existing coals. Never allow coal to build up above the top of the firebrick. When blue flame creeps up between the coals, drafts may be adjusted to maintain burn level. If the coal fire dies down before recharging, a fresh supply of kindling may have to be added.

## BANKING

Banking allows you to recharge in such a manner as to retain a hot coal bed throughout the night. Approximately an hour before retiring for the night, push the coals to the rear of the firebox with the coal tapered down in the front. Add a new layer of coal. Always leave some hot coals exposed in the front. This allows for more coal to be added to the firebox.

A coal fire should not be poked or broken up as this tends to bring ash to the surface of the coal bed where it may fuse. If the ash fuses, clinkers will form. It may be necessary to remove all unburned material and ash from the firebox to remove clinkers. These should be removed with gloves or tongs, and as always, put into a metallic air-tight container.

## BITUMINOUS RECHARGING

Because bituminous coal has a higher percent of sulphur and lower percent of fixed carbon than anthracite, recharging should be as follows:

Gently shake down grates, with drafts open and a good flow of primary air entering below the grates. Push the hot coals to the rear of the fire box and position fresh coal on the grate in front of the banked coal. As the fresh coal begins to burn, wood may be added to the top of the coal.

**NOTE:** Woodchuck recommends coal 1 inch to 3 inches in diameter. Ashes may be sifted through a mesh screen to reclaim particles of unburned coal.

## HELPFUL HINTS

Burning coal will provide a lesson in patience. Take the time necessary to experiment and understand the operation of your Woodchuck wood/coal furnace.

Too much draft air will cause clinkering of coal and will waste heat up the chimney. Shut draft down to as low a point as you can and still heat your home.

1. NEVER stand in front of loading door when opening it. Stand to the side.
2. NEVER completely cover the live fire with fresh coal. Always leave a generous area of burning coal at the top of the fire and at the rear.
3. Always keep the ash pit clean.

If the fire goes out or does not hold overnight look for:

1. Poor draft.
2. Incorrect damper settings.
3. Improper firing methods for coal being used.
4. More combustion air needed.
5. Coal not sized to furnace. We recommend 1" to 3" diameter pieces of coal.
6. Ashes, if allowed to accumulate in the ash pit, will not allow the required air for combustion. Keep ash pit clean.

## ASH REMOVAL

Ash should always be put into an air-tight, metal container.

### CAUTION

KEEP ASH PAN OUT OF UNIT DURING OPERATION. ASH PAN CAN GET VERY HOT. ASH PAN MUST BE PLACED ON A NONCOMBUSTIBLE SURFACE. NEVER USE ANYTHING BUT AN AIR TIGHT METAL CONTAINER TO DUMP YOUR ASHES IN. EVERY YEAR MANY FIRES ARE CAUSED BY EMPTYING ASHES INTO CARDBOARD BOXES OR PAPER BAGS. PROVEN FACT- SMALL RED EMBERS BURIED IN ASH CANS STAY RED HOT FOR DAYS. ASHES ARE A GOOD THERMAL INSULATOR AND KEEP ENOUGH OXYGEN AWAY SO THE EMBERS DO NOT BURN OUT.

Coal firing produces much more ash than wood. These ashes must be removed often (possibly daily) in order to avoid piling up too closely to the grates. Removal of the coal ash will prevent warpage and damage to grates, and allow passage of primary air to the coal bed.

Unlike wood ash, coal ash cannot be used as fertilizer. All coal contains small amounts of dangerous elements. It is therefore essential that your coal ash be disposed of in municipally designated areas.

## MAINTENANCE

### WARNING:

DISCONNECT APPLIANCE FROM ELECTRICAL SUPPLY BEFORE SERVICING UNIT. FAILURE TO HEED MAY RESULT IN SERIOUS PERSONAL INJURY OR DEATH.

Keep chimney and smoke pipe clean by cleaning at least twice during a heating season. Keeping your chimney and stove pipes clean is the best insurance against chimney fires.

If you clean your own chimney and stovepipe, Meyer Manufacturing Corp. recommends purchasing the same equipment professionals use. Brushes are available in enough sizes and shapes to snugly fit inside any common flue.

Replace any cracked or deteriorated firebrick. This will prolong the life expectancy of the firebox.

Check door gasket and replace as needed.

Oil blowers every 6 months of use. (SAE 10 motor oil required.)

Keep ash pit clean especially when burning coal.

Turn on your regular furnace once every month to keep it tuned up and limber.

### OPTIONAL CATALYTIC COMBUSTOR FOR MODELS 2900/4000

**NOTE:** Optional catalyst not recommended for Model 2900/4000 with 6" flue adapter. Smoke spillage may occur out of door when refueling.

Even with complete combustion there is a small amount of residue. Eventually enough will collect on the combustor to interfere with its operation. Therefore it is necessary to clean it periodically. To clean the combustor simply remove from unit and run tap water through it until no sign of residue remains. The combustor simply slides up into the exhaust pipe stub which protrudes down into the firebox. There are three rods on the combustor which engage slots in the pipe and then turn slightly to lock in place. These rods are not symmetrical so observe their orientation when you remove it. Two rods are welded at 90° and they point toward the rear of the firebox.

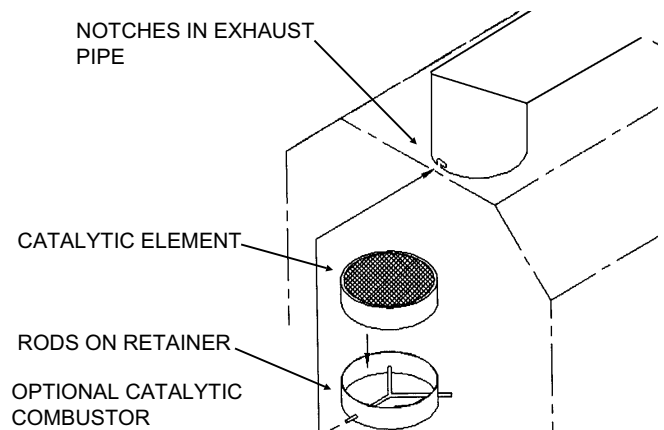

# TROUBLE SHOOTING

PROBLEM	POSSIBLE CAUSE	SOLUTION
1. Main blower vibrating when in use.	Loose Allen screw on squirrel cage.  Bad motor bearings.  Weights on squirrel cage wheel moved in shipment.	Tighten Allen screw, be sure squirrel cage did not move to one side or the other. Return blower to your local dealer for a replacement. Try to adjust it yourself or return blower for replacement.
2. Main blower continues to run.	Manual control turned on (fan/limit control).	Check fan/limit control switch. Push for manual, pull for auto. If in auto position, replace fan/limit control.
3. Main blower won't turn on.	Defective fan/limit control. Defective 3-speed blower switch. Defective circulation blower motor.	Replace. Replace. Replace.
4. Draft blower staying on.	Wall thermostat bad, check by turning temp. to 60° then check if draft blower is running. Short in thermostat wire. Home not getting heat needed to satisfy wall thermostat.	Replace wall thermostat.  Check all wiring again. Check on spec's chart to be sure your unit is large enough for your home. Be sure installation is proper: check with your local heating man.
5. Draft blower not turning on. <b>NOTE:</b> Be sure switch on blower is on.	Switch blower to the off position. Bad wall Thermostat; check by turning it up to 80° and if the draft blower does not turn on, replace thermostat. Lo limit bypass on "off".	Replace thermostat.  When starting up it is necessary to turn toggle switch on front of comfort control center to "on" until unit warms up.
6. Smell an odor from the first fire in the furnace.	New steel, small amounts of residue on the steel. Bad weld, if smell continues for two weeks of burning.	This will disappear in a matter of hours. Contact dealer immediately.
7. Not getting heat in the home.	Unit may be too small for your home; check specification chart. Improper insulation in home allowing heat to escape. Improper hookup to furnace. Ducting not sized properly for unit.	Replace with a larger unit or have regular furnace help. Reinsulate!  Check installation drawings and/or consult your local heating man.
8. Flames coming out the door when loading.	Excessive amount of gases on top of the fire box and igniting when given oxygen from open door. <b>NOTE:</b> This is one of your Woodchuck safety features built into every unit with a double latch system. Large amounts of unburned wood.	Try to load when fire is at its lowest point, but have enough embers left for a good start again. <b>NOTE:</b> Only you will know this time after some experience with your unit and installation.

PROBLEM	POSSIBLE CAUSE	SOLUTION
9. Excessive amounts of smoke coming out loading door when loading.	Improper draft.  Chimney cap too close to top of chimney. Too long of run of smoke pipe from Woodchuck to chimney.	Measure with draft gauge-should have .04 to .06 water column. Relocate. Relocate Woodchuck closer to chimney.
10. Puffing of smoke through draft control.	Improper draft.  Down draft on chimney.  Plugged chimney.	Check draft with gauge. Should be .04 to .06 water column. Check for cold spots on chimney or obstruction outside chimney. Trees or other buildings. Check with mirror in clean-out door or send cleaning brush down chimney. Check stovepipe connections.
11. Excessive dirt build-up around air vent in home.	Too much smoke escaping out of loading door when loading. Bad weld in fire box of unit. No return air ducting.	Check problem No. 9. Call dealer immediately. Install return air duct.
12. Improper seal around door.	Door rope not sealing on door frame.  Loose door from shipment.	Check door rope so that all parts of door frame are sealed, especially corners. Simply bend door latch in to tighten door seal.
13. Excessive creosote build-up.  A reminder, whatever kind of fuel you burn, there is some kind of residue build-up on the furnace and chimney. Same with wood no matter how good the conditions.	The use of wet, frozen, or unseasoned wood.  The use of soft wood, particularly those of high resin content such as plywood or blandex with glue. Poor natural draft or an obstruction in the stove pipe or chimney flue.  Too long of burning times. Inadequate amount of oxygen supplied to the combustion chamber  Low fire or flue gas temperatures.  Uninsulated stovepipe or chimney flues, especially if construction is exterior to the house.  Air leaks in the stove pipe or chimney.	If you have to use wet wood, make loads smaller and burn them hotter. Avoid using if possible.  Measure draft with gauge. Should have a minimum of .04-.06 water columns of draft. Smaller and hotter fires. Adjust draft for hotter fires or in some homes, it has been determined there was not enough in the basement due to such an air-tight home. We recommend 4" round hole to the outside with a screen on to keep varmints out. Smaller loads of wood and hotter fire. Stack temps. should maintain minimum 300° to 400°. Never use uninsulated pipe for chimneys installed on the outside of the house, INSULATE! Check chimney from top to bottom. <b>NOTE:</b> Creosote is a tarry liquid or solid coming from distillation of wood during the combustion process. The heavier buildups, the greater chance of a chimney fire. <b>NOTE:</b> No matter how seasoned the wood, no matter how good the draft, you always will get a small amount of soot buildup. Should be cleaned before winter firing and during mid-winter's firing.

# INSTALLATION

## GENERAL REQUIREMENTS

### CAUTION:

EQUIPMENT MUST BE INSTALLED BY A QUALIFIED HEATING PERSON.

### CAUTION:

ONLY "CLASS A" ALL-FUEL OR SOLID FUEL CHIMNEYS INTENDED FOR USE WITH YOUR WOODCHUCK SHOULD BE USED.

FIRST AND ABOVE ALL is safety for you and your family.

**MUST USE:** Class A Masonry or ULC listed, manufactured Class A All Fuels Chimney.

**RECOMMENDED SIZE:** Rectangular 8"x12" or Round 8".

**DO NOT CONNECT THIS UNIT TO A CHIMNEY FLUE SERVING ANOTHER APPLIANCE.** The Woodchuck is to be used in conjunction with a listed gas or oil fired furnace or as a central furnace.

**ELECTRICAL SUPPLY:** 115 volts, 60HZ, 1 Phase, less than 12 amps.

Install system with 0.2 static pressure.  
Flue setting .06 W.C. Max to .04 W.C. Min.

Wood or coal related fires are caused almost exclusively by installation, operation or maintenance errors; but not by unsafe equipment.

**IMPORTANT:** Check with your local state and federal codes on installation at your local fire department.

## PLACEMENT AND MINIMUM CLEARANCES

### CAUTION:

FURNACE MUST BE INSTALLED ON A NON-COMBUSTIBLE FLOOR OR 3/8" THICK FIREPROOF MILLBOARD OR EQUIVALENT.

Locating your unit is very important for proper draft and most efficient heating possible. See figure 7.

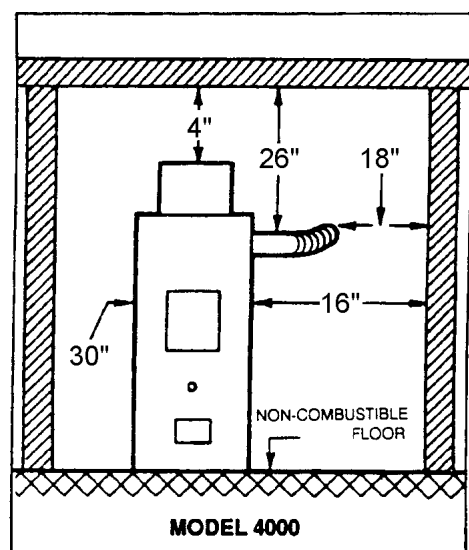
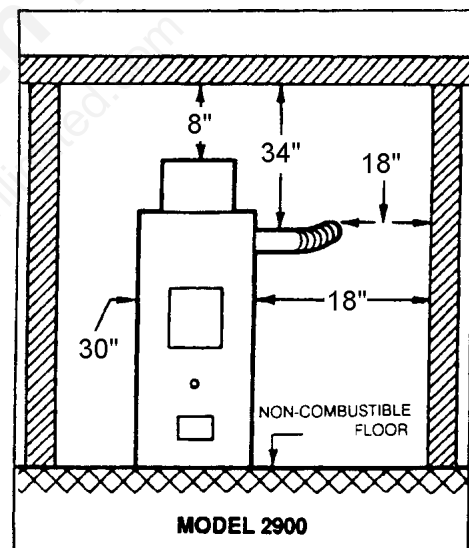
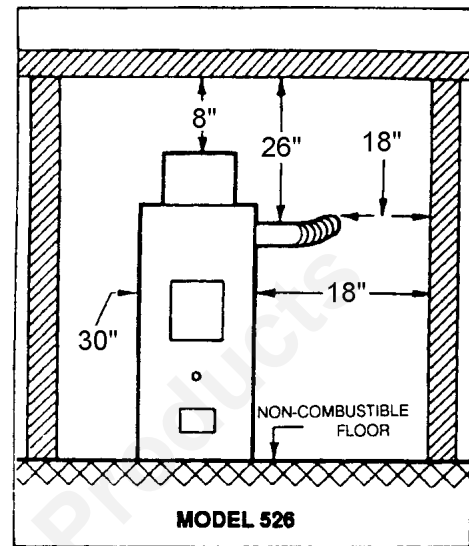

FIGURE 7 LOCATING THE WOODCHUCK

THE CAP SHOULD BE SUCH THAT IT HELPS TO PREVENT DOWNDRAFT WHILE PROVIDING ADEQUATE EXHAUST DRAFT.

TOP OF CHIMNEY MUST BE AT LEAST 2' HIGHER THAN PEAK OR HIGHEST PORTION OF ROOF WITHIN 10' HORIZONTALLY. ALSO SEE FIGURE 9.

A CHIMNEY WHICH RISES WITHIN HOUSE IS BETTER INSULATED THAN A CHIMNEY WHICH IS LOCATED OUTSIDE THE HOUSE AND IS EXPOSED TO WEATHER.

THE CHIMNEY FLUE MUST HAVE A CROSS SECTIONAL AREA AT LEAST EQUAL TO OR LARGER THAN THAT OF THE STOVES FLUE COLLAR; BUT NO MORE THAN TWICE THAT AREA.

THE CHIMNEY THIMBLE SHOULD BE CONSTRUCTED OF FIRE CLAY AND SHOULD HAVE AN INSIDE DIAMETER WHICH IS NOMINALLY EQUAL TO THE OUTSIDE DIAMETER OF THE SMOKE PIPE TO ASSURE A REASONABLY AIR TIGHT FIT. THE THIMBLE MUST NOT EXCEED BEYOND THE FLUE LINING.

MIN. 3' FROM TOP OF CHIMNEY TO POINT AT WHICH IT PASSES THROUGH THE ROOF

RECOMMENDED MIN. HEIGHT APPROX. 20'

FLUE SHOULD BE OF CONSTANT CROSS SECTIONAL AREA THROUGHOUT ITS LENGTH

CLEANOUT DOOR SHOULD BE PROVIDED AND IT MUST HAVE AN AIRTIGHT FIT. IT SHOULD NOT BE LEFT OPEN FOR ANY LENGTH OF TIME WHEN STOVE IS IN OPERATION

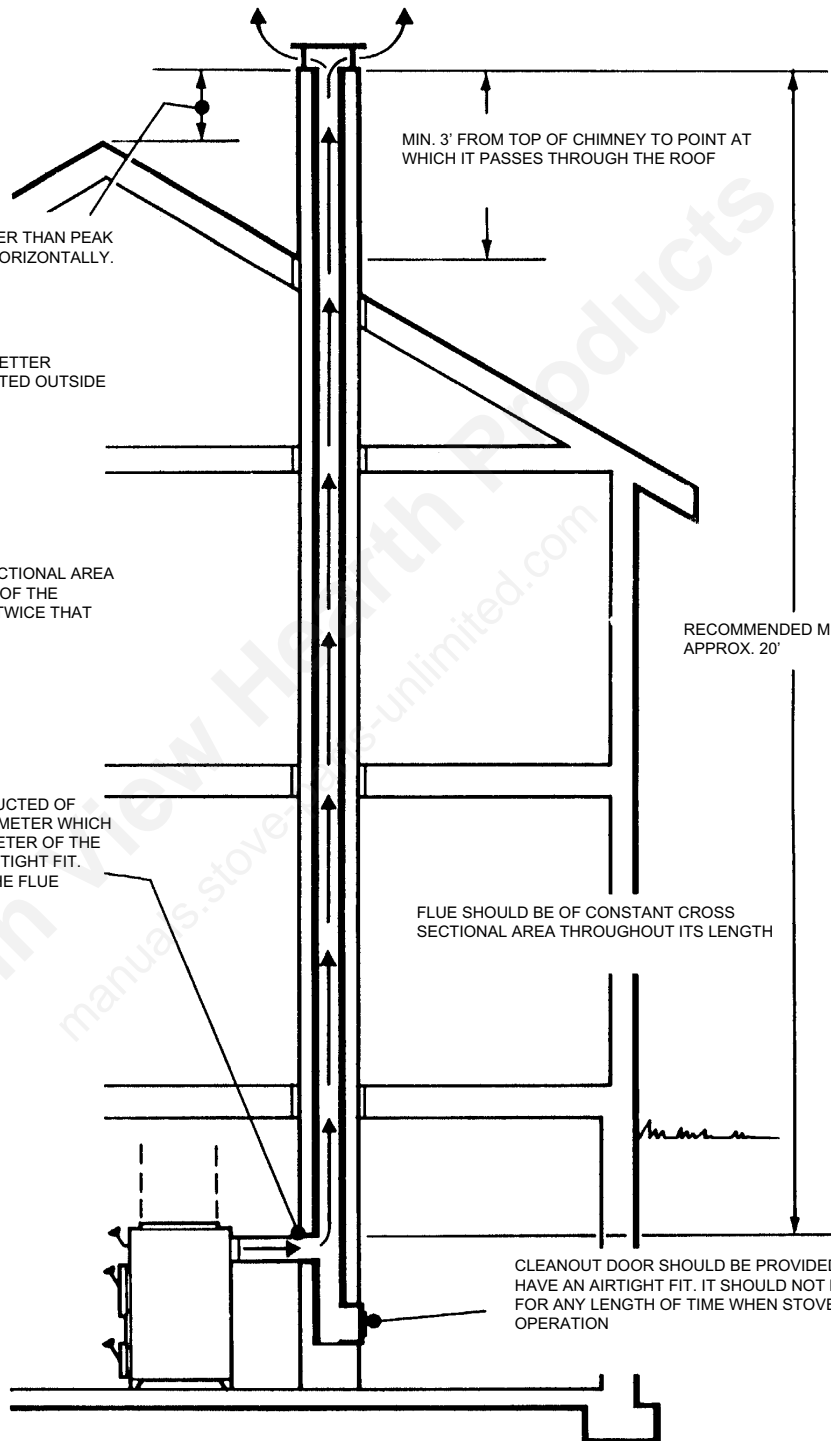

FIGURE 8 TYPICAL CHIMNEY CHECKLIST

Your unit should be placed on a non-combustible floor or 3/8" thick fireproof millboard or equivalent which extends at least 8" from the sides and rear and extends 24" from the front. Leave a minimum clearance of 36" in front of your unit. This is for safe, easy loading and cleaning of your unit.

Also be sure to allow enough room at the rear of the Woodchuck for installation of the circulating blower and filter box.

If using your unit as an add-on, 6" minimum clearance is required from your present furnace.

One very important step in locating your wood/coal furnace is how much distance you will be from your new or existing chimney. The unit should be installed as close to the chimney as possible with a minimum of elbows (no more than 2) and no more than 6 feet horizontally with 1/2" rise per foot.

## CHIMNEY INSTALLATION

It is extremely important that your Woodchuck furnace be installed into a CLASS A CHIMNEY ONLY. These chimneys consist of a **flue-lined masonry chimney** or an approved Class A **All Fuel factory built metal type**. Any other installation constitutes a fire hazard, as wood and coal burning units have stack temperatures as much as 300° to 1000° and may also deposit creosote

which can ignite and cause severe damage to any chimney. **MAKE SURE YOUR WOODCHUCK IS INSTALLED INTO A PROPER CHIMNEY.**

For maximum safety and efficiency never install the Woodchuck furnace into the same chimney serving another appliance.

A typical chimney checklist of requirements is depicted on figure 8.

The Model 526 furnace is equipped with a 6" flue collar having 28 sq. in. of exhaust area. Models 2900 and 4000 have an 8" flue collar having 50 sq. in. of exhaust area. When connecting the furnace to the chimney maintain a chimney flue section giving these minimum areas or larger but not exceeding twice this area. Some common sizes that are acceptable are 8" round, 10" round, or 8"x12" rectangular. All Woodchuck furnaces must be installed into a chimney developing a minimum of .04 W.C. to a maximum of .06 W.C. inches of draft. To maintain this range of draft, a barometric damper should be installed (see pgs. 18-20) on each unit when the draft from the chimney is capable of exceeding .06 W.C. inches of draft.

Insufficient draft can contribute to smoke spillage when the loading door is opened and to rapid creosote accumulation. Excessive draft can cause high flue gas temperature, loss of overall efficiency and effect the degree of control the operator can exert on the unit.

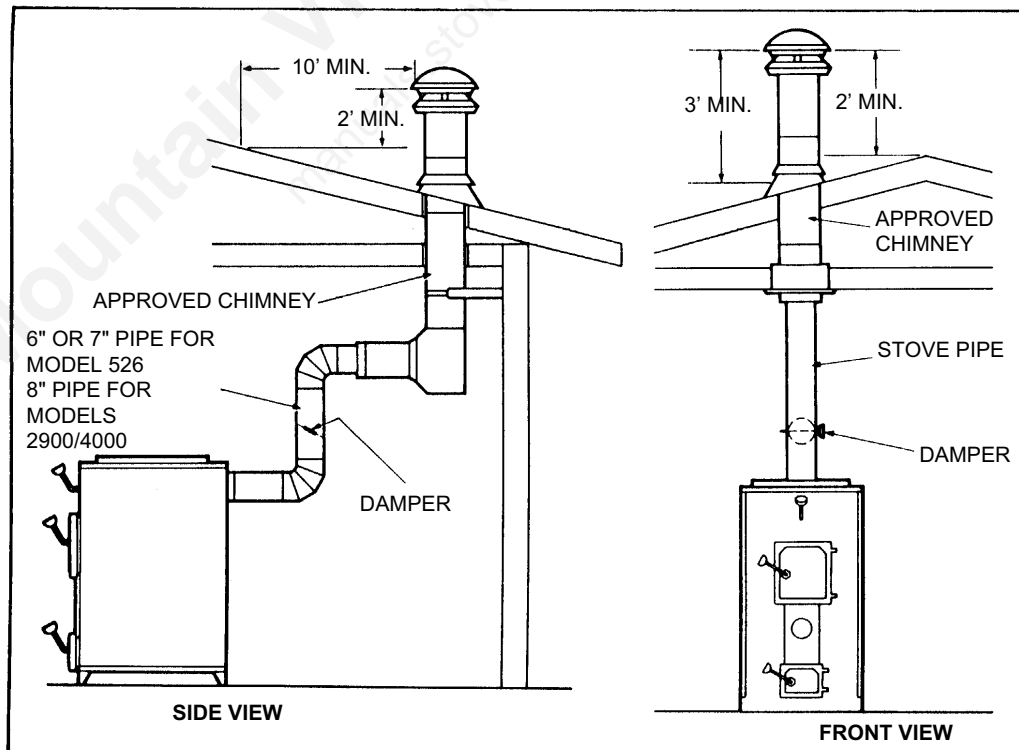

**FIGURE 9 CHIMNEY/ROOF CLEARANCE  
TYPICAL STOVE PIPE INSTALLATION**

When using approved factory built metal chimneys, you must have at least 2" of clearance when going through a wall or next to a wall. A typical factory chimney installation is shown on figure 9.

## INSTALLING YOUR WOODCHUCK

Most of the Woodchuck furnace is factory assembled. The factory assembly should be located as detailed in the PLACEMENT AND MINIMUM CLEARANCES section and on figure 7.

Remaining assembly will consist of mounting the controls, draft and circulating blowers, filter box if used, and electrical connection. These details will be provided after stove pipe and air duct installation.

## STOVE PIPE INSTALLATION

Install your Wood/Coal unit as close to the chimney as possible with a minimum of elbows. We recommend no more than two elbows. The maximum horizontal run should not exceed 6 feet with a 1/2" rise per foot. The pipe should maintain a 1/2" rise per foot and NEVER be installed closer than 18" from combustibles. Exceeding these recommendations normally represents creosote build-up, a smoking furnace, or one with poor draft.

When connecting stove pipe, all joints should be secured with at least three #10 sheet metal screws.

**NOTE:** If it is absolutely necessary to make a run greater than 6 feet (not recommended), use extra support brackets every 3 ft.

The connection to the wood furnace's collar must also be more than just a snug fit. Drill holes through the Woodchuck's collar and secure with sheet metal screws. Mark each connection for cleaning. This will prevent frustration when matching up your hole pattern again.

### DAMPERS IN STOVE PIPES:

A manual damper may be installed at a safe convenient place between the barometric damper and the chimney. In the event of chimney fire, it can quickly be closed reducing draft to the chimney. See figure 10.

SUGGESTED TYPE  
DAMPER

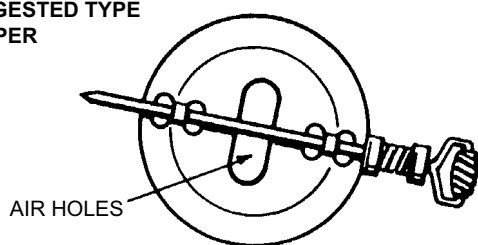

## INSTALLATION OF A BAROMETRIC DRAFT

Some codes and NFPA require draft regulators in the chimney connector of wood or coal furnaces and boilers, and manufacturers recommend their use with some stoves. There is some doubt among wood heat experts as to whether use of barometric draft regulators is wise.

Draft regulators limit the draft-the suction pulling air into the appliance. A pivoted, counter-balanced flap is pulled open by the draft when the draft reaches a critical amount (figure 10). This permits air to enter the chimney, thus preventing the draft in the appliance from rising any higher.

Use of draft regulators with oil-fired equipment is common. One objective is to keep the oil flame from being blown out by excessive draft. This is more an annoyance than a safety problem since most oil burners have primary safety controls which stop the fuel flow into the burner whenever the flame goes out, and modern flame-retention burner design makes draft regulation almost unnecessary for this objective.

A second objective is to limit the amount of air passing through the system in order to maintain high heat transfer efficiency. Another desirable consequence is a decrease in peak chimney temperatures due to the added air entering through the regulator.

High draft does not blow out the flames but fans them in wood and coal burning equipment. An especially hot fire can result. Control of the fire may be difficult, particularly if the wood burner is not airtight. Energy efficiencies may be adversely affected, and chimney fires may be ignited. A barometric draft regulator can alleviate these problems by limiting the flow of combustion air into the appliance and by adding cooling air to the hot flue gases.

However the cooling air may result in more creosote accumulation, and if a chimney fire does start, it will be more intense because of the draft regulator. Large flows of air into the regulator will fan the fire in the chimney. Thus the net effect of barometric draft regulators is unclear-they help in some aspects, and hurt in others. Note, though, that if a chimney is clean so that chimney fires are impossible, a draft regulator does no harm, and does help limit the intensity of the fire in the appliance, and it helps prevent the flue gases in the chimney from getting too hot. Barometric draft regulators are recommended by JFPA for hand fired thermostatically controlled solid fuel furnaces.

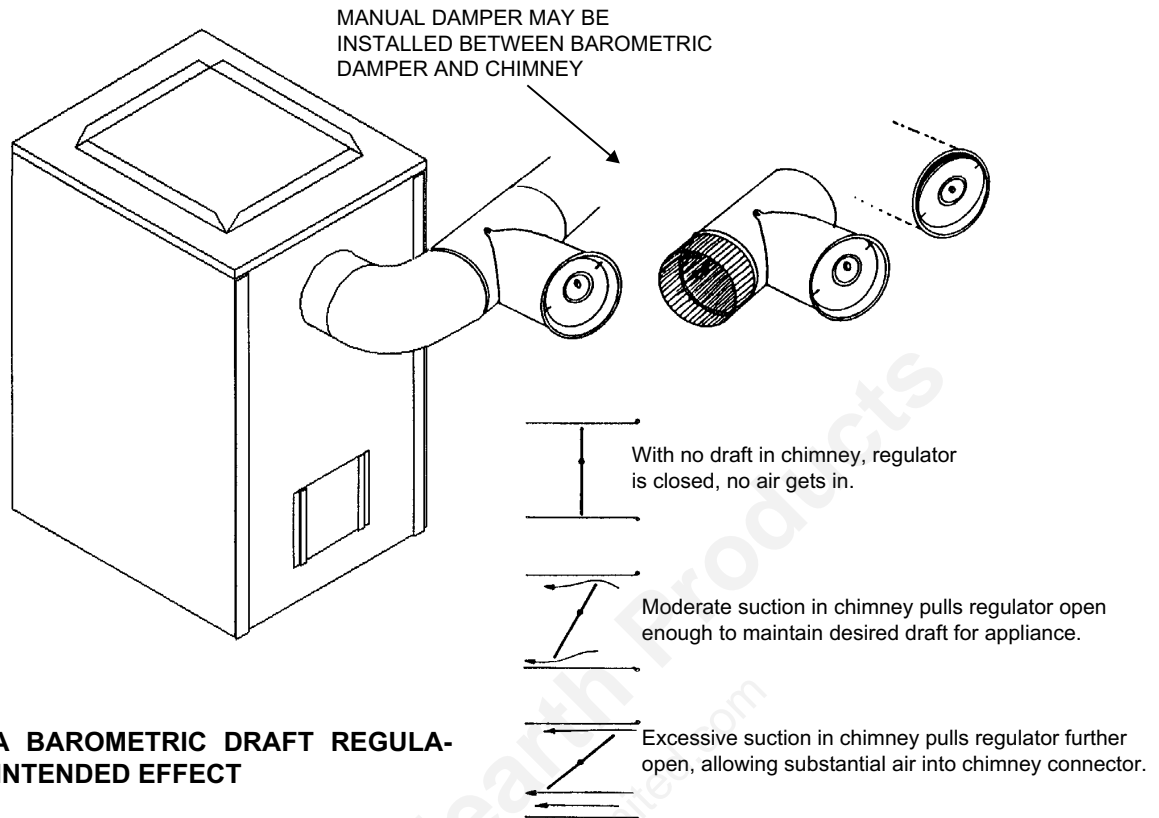

**FIGURE 10 A BAROMETRIC DRAFT REGULATOR AND ITS INTENDED EFFECT**

## AIR DUCT INSTALLATION

### SPECIAL AIR FLOW CONSIDERATIONS FOR WOOD/COAL FURNACES

With Wood/Coal furnaces, a special concern is preventing wood joists and flooring close to the hot air ducts and plenum from overheating. A fire hazard is created by the hot air flow circulating through ducts not designed for such high temperatures. Most Wood/Coal furnaces produce much hotter air than oil or gas fired units. So most clearances from the existing ducts and plenum are usually inadequate with a supplemental Wood/Coal furnace installation.

When installing the air duct, follow recommended clearances shown in figure 11.

The plenum on the Woodchuck should be 20"x23" and no less than 18" high while maintaining a minimum of 18" clearance to the ceiling or other combustible material. In a power outage situation, excessive heat buildup at the plenum top may be dangerous, so make sure clearances are maintained. For the Model 4000 allow at least 4" from ceiling to plenum.

The ducts, fittings, grilles and registers should be sized so that the total external static pressure does not exceed .02 W.C. inches while developing air velocities

of 600 ft/min to 1000 ft/min at the registers. NEVER supply less than 150 sq. in. of heated air outlet area.

Cold air returns must be at least equal in size to the heated air outlets and preferably 10% larger. Every Woodchuck furnace MUST be installed with a cold air return.

### ADD-ON INSTALLATIONS

Before installing your Woodchuck furnace, consult your furnace man and local state building codes to determine if your furnace will accept an add-on application. Some small furnaces and especially counter-flow furnaces may not be used in add-on installations.

Once it has been determined that your existing furnace will accept an add-on installation, we recommend a parallel installation, with direct (ducted) feed of return air to the Wood/Coal furnace, see figure 12. The back flow prevent damper assures that when either unit is operating by itself, the hot air will flow into the home, and not flow back through the other furnace.

Figure 13 shows a central installation.

We do not recommend supplemental wood furnace installations with series connection. These types of installation are not advisable in spite of their simplicity, see figure 14.



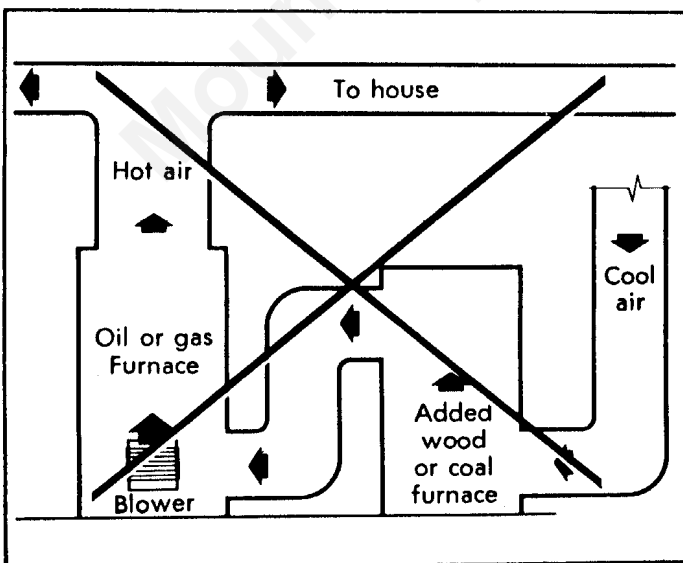
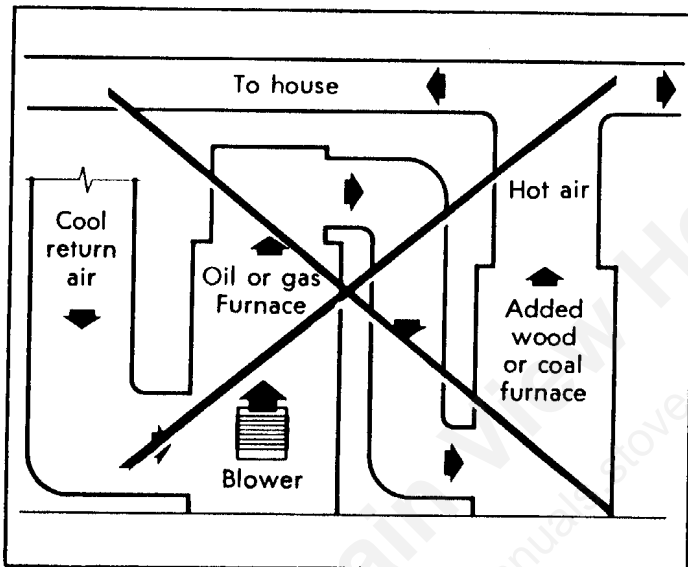
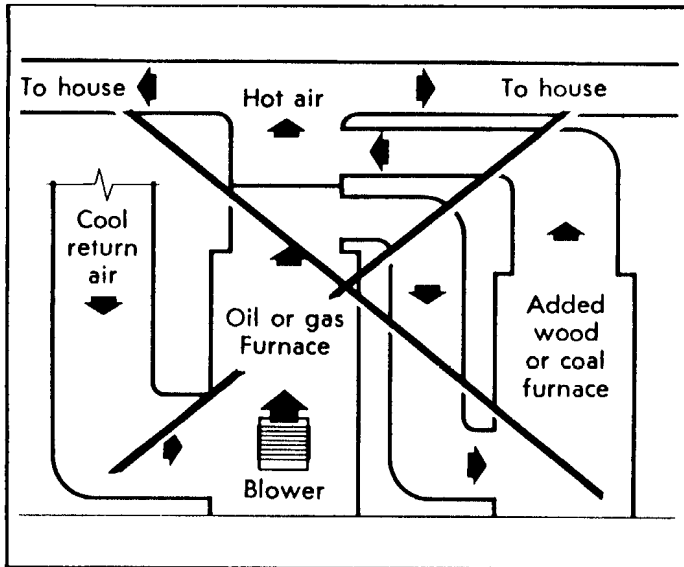

FIGURE 14 POOR INSTALLATIONS

4. Assemble the right front bar to a rear bar. Slide a gear onto the front shaft, aligning it to engage the gear on the left bar. Place the front bar onto the front frame and then setting the rear bar onto the rear frame.

5. Place rear retainer in place, then the center and the front retainers. Place all four bolts through retainers and frame. Secure with locknuts. To prevent binding, it is advisable to snug the locknuts but do not over tighten.

6. Try moving the shaker grate bars with the handle. **NOTE:** Both bars in normal position should be flat. If not, one or the other gear is not aligned correctly.

7. To install the assembly into the unit, place the front end of the assembled grate on the loading door lower frame. The grate should be the upside down position. Slide the grate (front end first) into the firebox allowing the front end to lower into the hearth area. Once the back end of the grate has cleared the door frame, "flip" it over toward the rear of the unit. If necessary, reach into the ash pit door and pull the front of the grate forward until it lodges into place.

### INSTALL SHAKER GRATE HANDLE, MODEL 2900 ONLY

1. Open the door ash door. Slide the shaker grate handle through the opening in the side of the door frame and guide it through the actuator arm and into the receiving boss on the opposite side of the frame.

2. Secure handle to actuator with 1/4x1-1/2 bolt and nut. See figure 15.

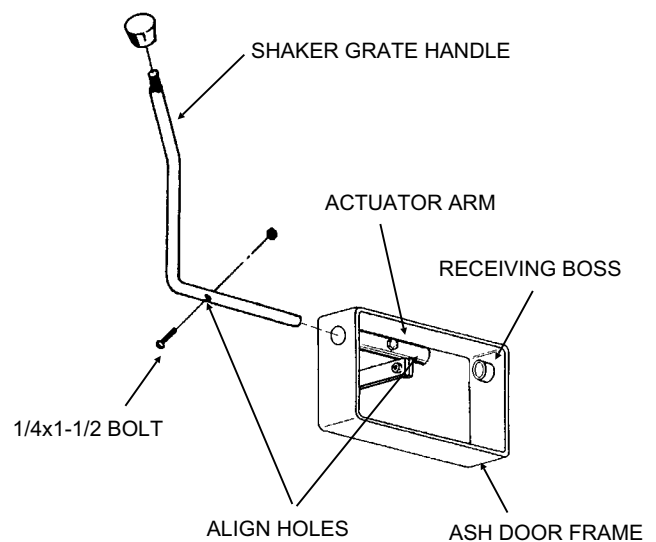
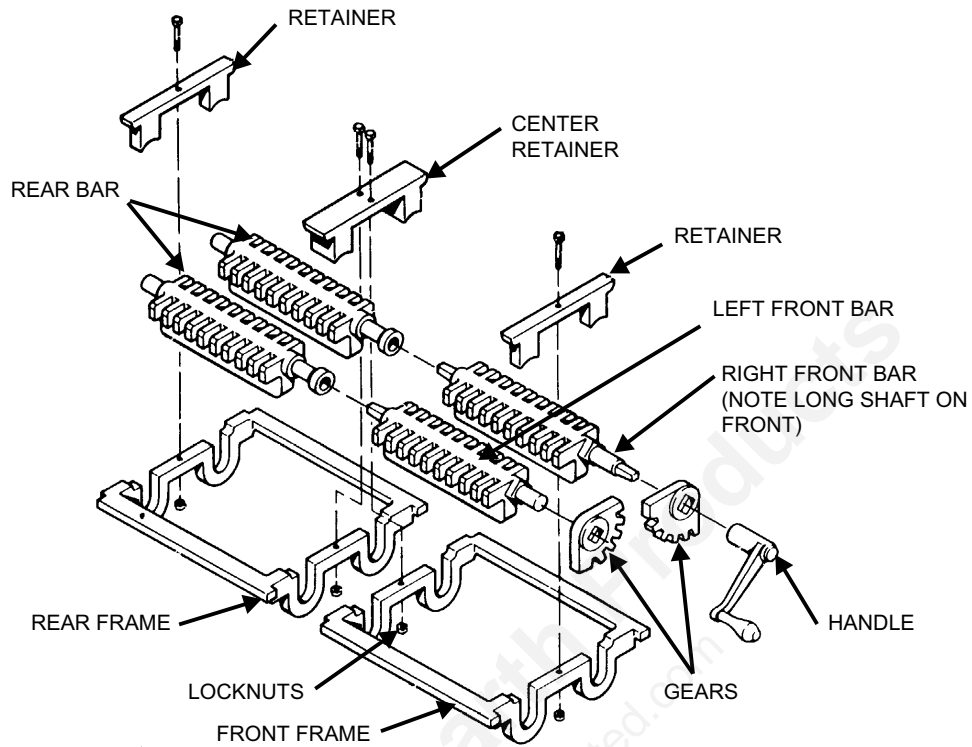

FIGURE 15 INSTALL SHAKER GRATE HANDLE



**FIGURE 16 INSTALL OPTIONAL SHAKER GRATE FOR MODEL 526**

## INSTALL FIREBRICK

Place firebrick into unit as follows:

1. Place two longer bricks with bevel cuts against the rear wall of the firebox. See figure 17.
2. Place remaining two bricks with bevel cuts against the front wall of firebox.
3. Place rectangular brick along side walls of firebrick as illustrated. If Rectangular bricks are two different widths, then an equal number of each will go on both sides of firebox.

### INSTALL OPTIONAL CATALYTIC COMBUSTOR (MODEL 2900/4000)

**NOTE:** Optional catalyst not recommended with 6" flue adapter. Smoke spillage may occur out of door when refueling.

Greater efficiency can be obtained when burning wood by use of a catalytic combustor. In addition, it will decrease the accumulation of creosote and diminish the possibility of a chimney fire.

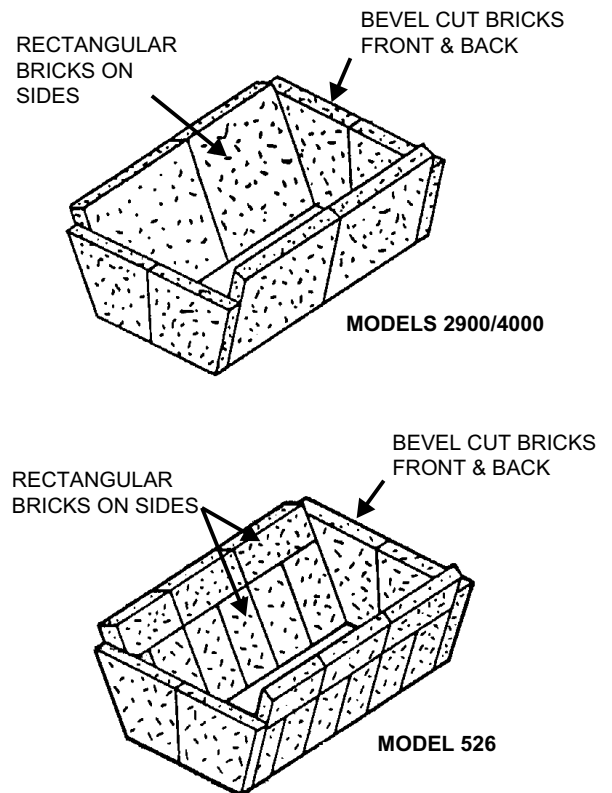

**FIGURE 17 INSTALL FIREBRICK**

The pyrolysis of wood produces certain substances which will not burn unless the temperature in the firebox reaches 1000°F or higher. Under normal conditions these temperatures are not attained and these substances simply escape up the chimney as wasted energy and can form deposits in the chimney. By forcing these unburned substances to come into contact with a catalyst, we can cause them to burn at much lower temperatures that are easily attainable during normal operation.

Installation and removal of the combustor is simple, the element fits inside a retainer. The retainer fits inside the furnace exhaust pipe which extends down into the firebox. The assembled combustor slides up into the exhaust pipe stub which protrudes down into the firebox. There are three rods on the retainer which engage slots in the pipe and then turn slightly to lock in place. These rods are not symmetrical. Two rods are welded together to form a 90° angle. This angle points toward the rear of the firebox.

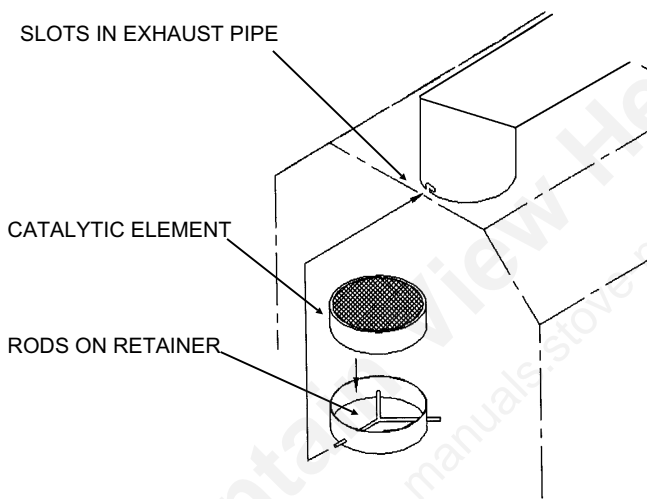

**FIGURE 18 INSTALL OPTIONAL CATALYTIC COMBUSTOR (MODEL 2900/4000)**

### ASSEMBLE MANUAL DRAFT MODEL 526 ONLY

Using a 1/4x1-1/2 bolt and locknut, mount manual draft control onto the draft channel, figure 19. If you are going to install optional forced draft, disregard. Do not tighten too tight to damper draft adjustment, but not too loose to let more air in than required. DO NOT remove knockout on draft channel. Locknut can be held with wrench inserted through air opening.

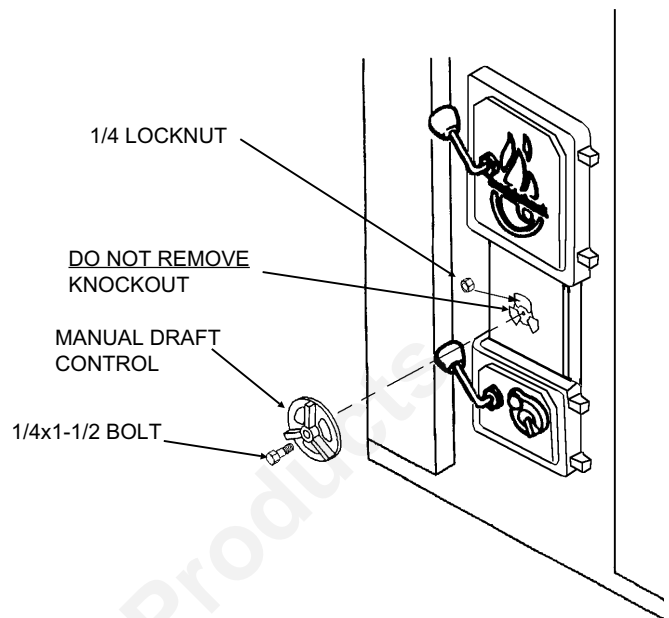

**FIGURE 19 INSTALL MANUAL DRAFT-MODEL 526**

### INSTALL COMFORT CONTROL CENTER AND FORCED DRAFT BLOWER

1. Install all knobs to control levers and door handles. See figure 20.
2. The comfort control center is factory wired to the fan/limit control and the forced draft blower. It has a prewired flexible conduit for connection to the circulating blower.
3. If you have optional temperature gauge on your control, then strip 1/2" of insulation from the two leads of thermocouple wire protruding through the rectangular opening on the furnace side. Connect these leads to the terminals on the temperature gauge of the control. **IMPORTANT:** Remove the wire ground clip from the terminals of the gauge and connect White wire to + terminal and Red wire to - terminal. See figure 22.
4. Mount the control to the side of the furnace with four #10 sheet metal screws.
5. Remove the knockout section of the draft channel on model 526 by striking sharply with a hammer. Be careful so you do not damage the mechanism inside the channel and directly behind the knock-out. DO NOT allow the knock-out to fall inside the draft channel.
6. Align the forced draft blower outlet flange over the knockout and secure with three #10 sheet metal screws.
7. Secure conduit to furnace side using conduit clamps and #10 sheet metal screws.

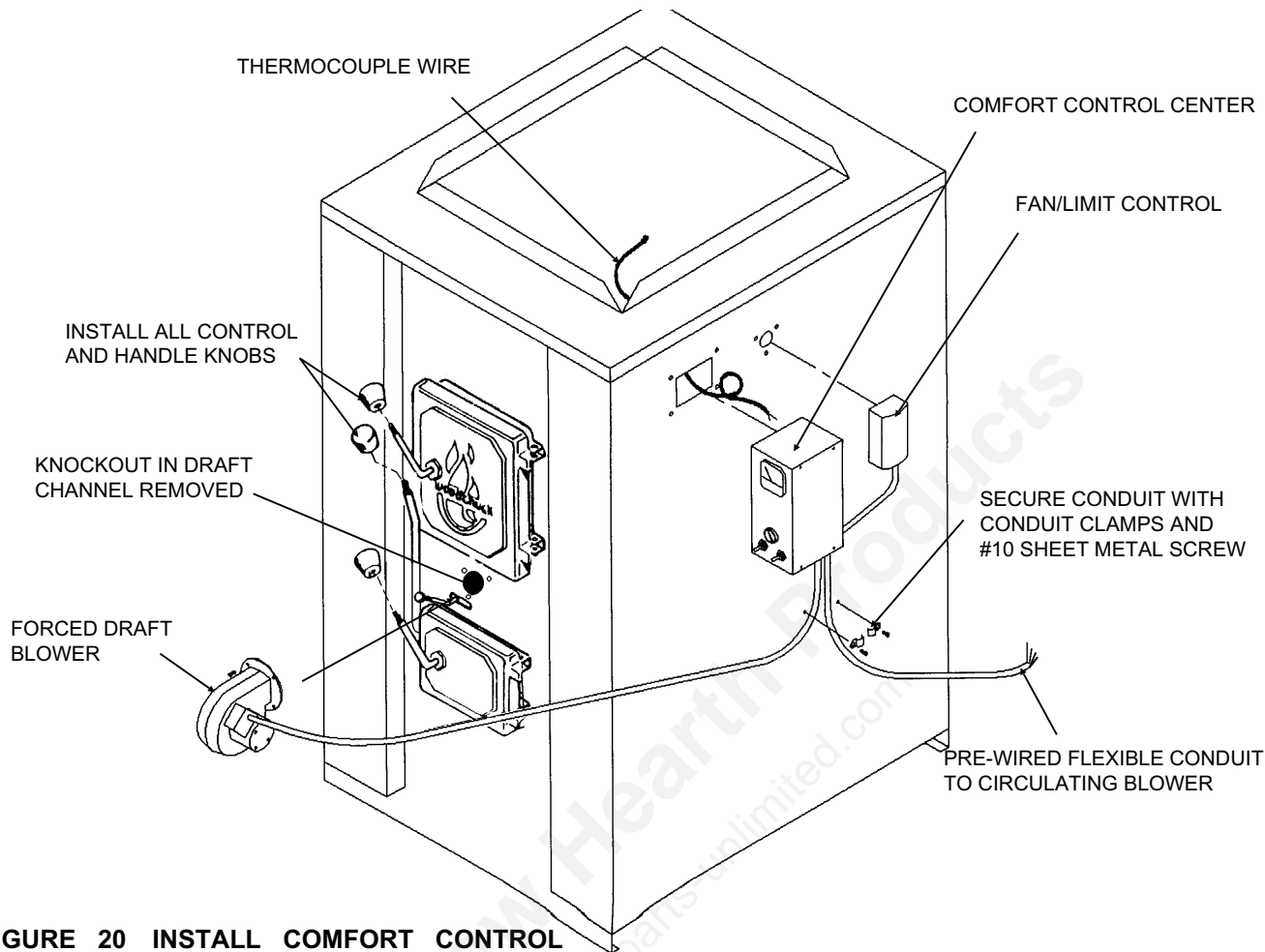

**FIGURE 20 INSTALL COMFORT CONTROL CENTER AND FORCED DRAFT BLOWER**

### INSTALL CIRCULATING BLOWER

The flanges on the circulating blower simply slide behind the angle mounts welded to the rear of the furnace. Slide in from the top side, figure 21.

### INSTALL FILTER BOX

The filter box is standard on Model 526. Installation instructions are included with Model 526 filter box.

1. The filter box can be installed with the filter on either side. The access door will fit the opening either side and the handle should face forward.
2. Find two factory shipped support angles. Force support angle sides without tabs into the groove of the mounting strip on both rear sides of the furnace. Position at correct height to accept filter box, figure 21.

3. With filter box set against back of furnace, bend down the tabs on the support angles so they lock behind the flanges of the top and bottom panels of the box.

4. Install the access door. Install filter not supplied and install a cold air return system to the filter box filter side opening.

5. Route flexible conduit from comfort control through hole in top panel and to box connector on blower connection box. Connect wires to blower motor by joining wires of the same color.

FEED	MOTOR
White	White/Purple
Red	Red
Blue	Blue
Black	Black

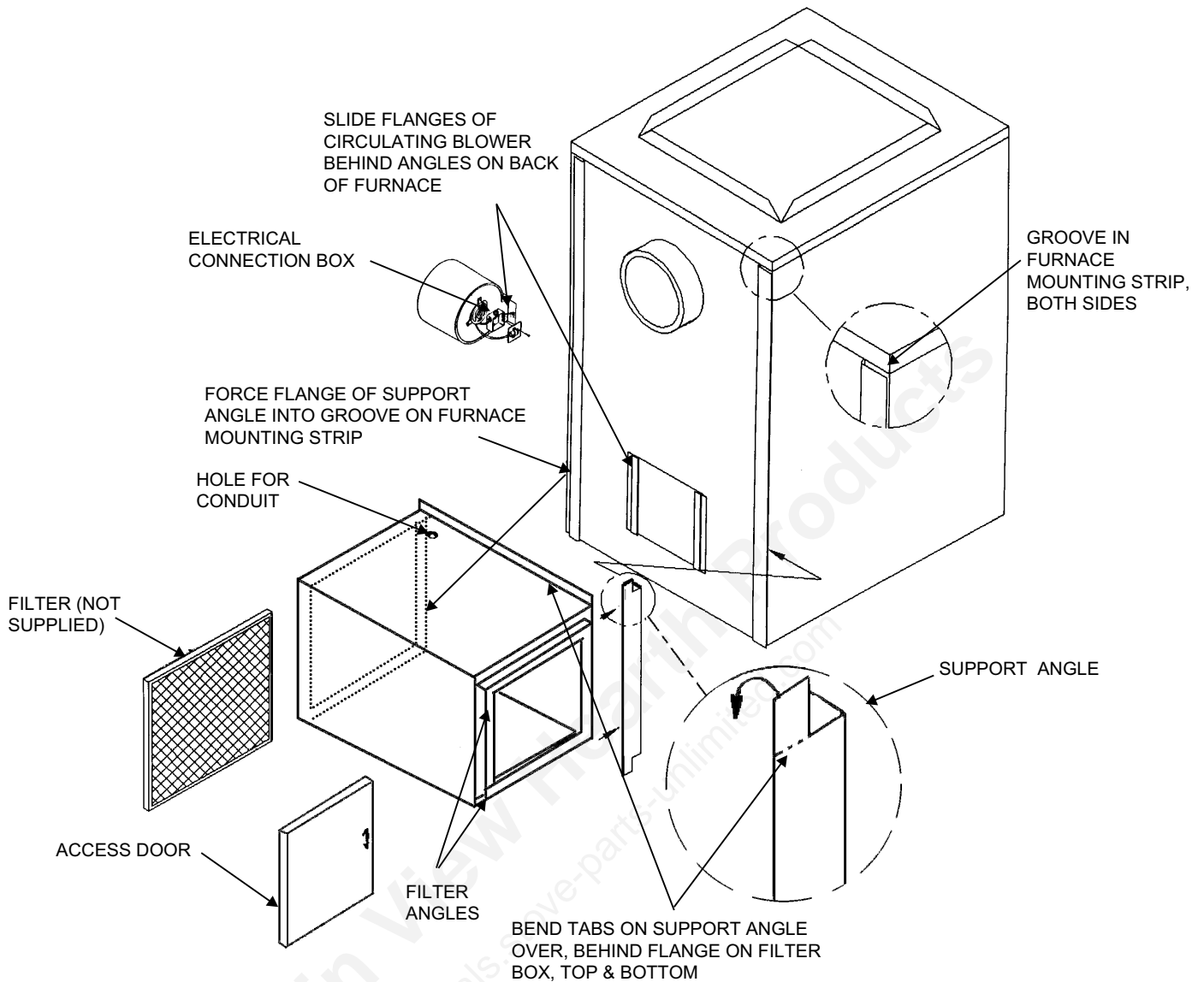

**FIGURE 21 INSTALL CIRCULATING BLOWER AND FILTER ELECTRICAL HOOKUP (FIGURE 22)**

1. If you have an optional temperature gauge to monitor heat exchanger temperature in your comfort control center, then the thermocouple wires must be connected to the gauge when installing the control. See figure 20.

**IMPORTANT:** Remove the wire ground clip from the terminals of the gauge and connect White wire to + terminal and Red wire to - terminal. See figure 22.

2. A prewired conduit is connected to the comfort control center for the circulating blower. The opposite end is to be connected in the junction box on the blower motor. Connect like colored wires. Secure conduit to junction box with box connector.

3. The comfort control is factory wired to the forced draft motor (optional on Model 526). If you have the forced draft, locate a wall thermostat in the desired location of your house and run #18 thermostat wire (not furnished) from this thermostat to **R** and **G** terminals of the trans-

former in the comfort control. These connections have been routed to a terminal strip on the outside of the comfort control box for convenient connection.

4. The circulating blower limit control is factory wired to the comfort control center. Jumper removed, normal fan limit control settings are 160°F ON, and 110°F OFF.

5. Route 110VAC power through conduit from your power supply to the comfort control center box. Route through box connector provided and connect hot (L<sub>1</sub>) to **BLACK**, Neutral to **WHITE** and ground to **GREEN** as shown on figure 22. You must provide a power disconnect in the power supply line to your furnace which is within sight of the Woodchuck and not more than 30 feet away. Your circuit breaker at the power supply may meet these requirements.

**⚠ WARNING:**

ELECTRICITY CAN KILL, SHOCK, OR BURN. DISCONNECT AND LOCKOUT POWER SOURCE BEFORE SERVICING OR INSTALLING ELECTRICAL COMPONENTS. FAILURE TO HEED MAY RESULT IN SERIOUS PERSONAL INJURY OR DEATH.

**⚠ CAUTION:**

ALL WIRING MUST MEET LOCAL, STATE AND NATIONAL CODES AND BE INSTALLED BY A QUALIFIED ELECTRICIAN.

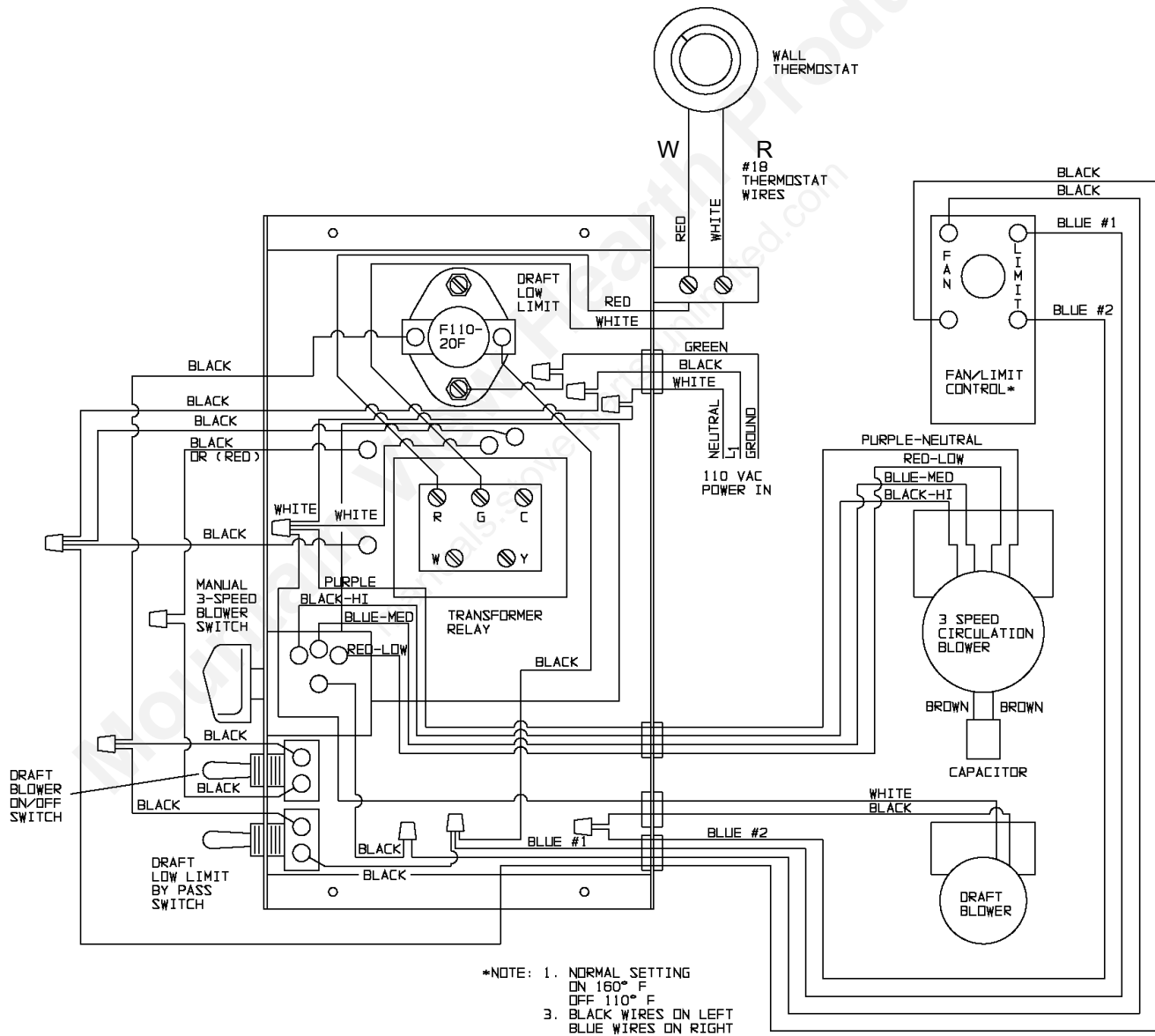

**FIGURE 22 ELECTRICAL WIRING DIAGRAM**

# REPAIR PARTS

## BASIC UNIT FOR MODEL 526

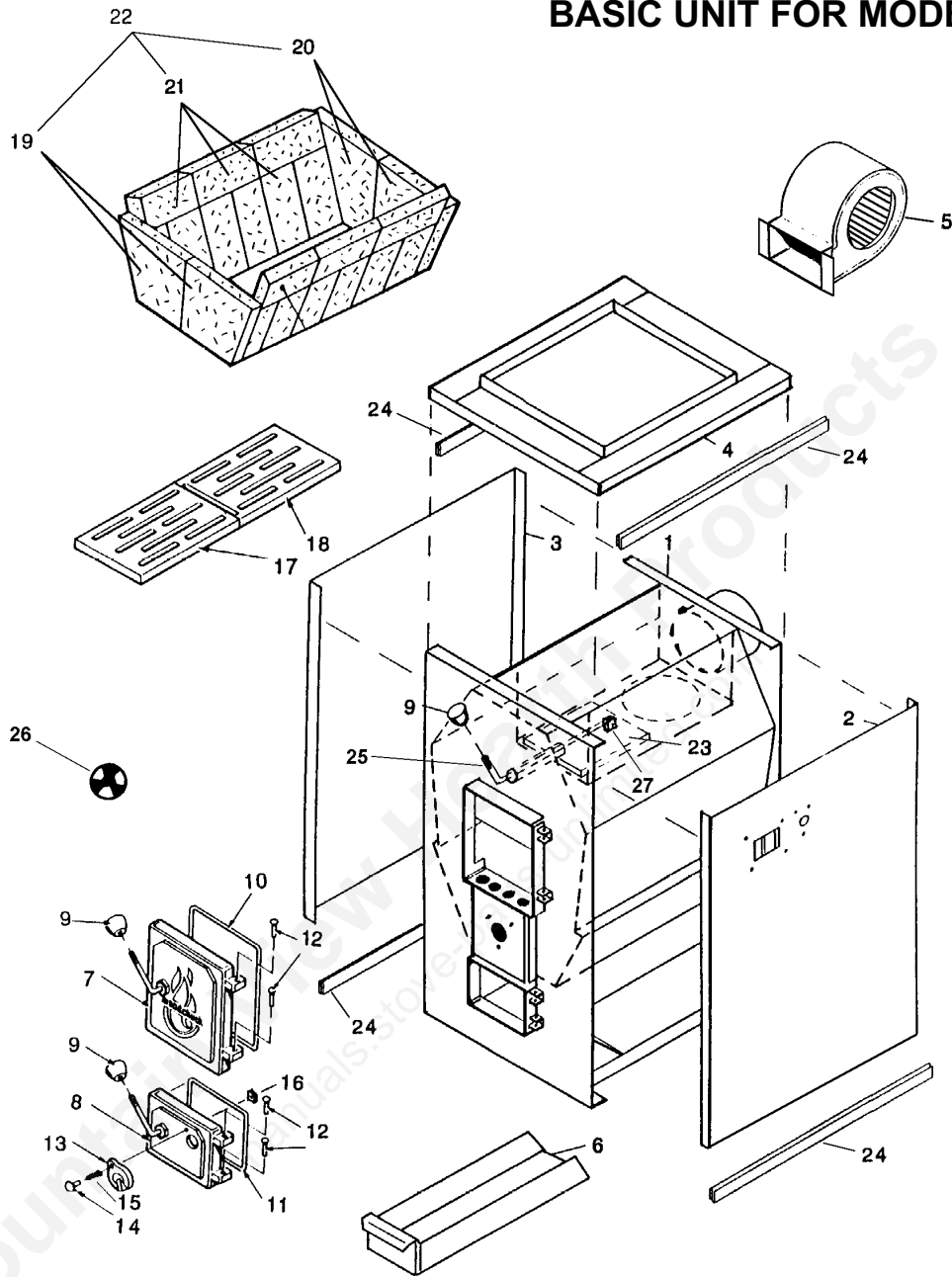

KEY NO.	PART NO.	DESCRIPTION
1	01-0526	Welded Assembly
2	03-5262	Shroud - Right Side
3	03-5263	Shroud - Left Side
4	03-5261	Shroud - Top
5	08-0005	Circulation Blower
6	06-1001	Ash Pan
7	02-5261	Fuel Door
8	02-5262	Ash Door
9	06-1014	Door Knob
10	06-5261	Fuel Door Gasket
11	06-5262	Ash Door Gasket
12	06-0200	1/4 Door Pin
13	05-0004	Handle Access Cover
14	801-2520-1.5Z	1/4x1-1/2 Bolt

KEY NO.	PART NO.	DESCRIPTION
15	06-0215	Spring
16	814-2520-Z	1/4 Lock Nut
17	05-0002	Small Grate
18	05-0001	Large Grate
19	07-5263	Front Brick Kit (2 pc.)
20	07-5262	Rear Brick Kit (2 pc.)
21	07-5261	Side Brick Kit (18 pc.)
22	07-5260	Complete Brick Kit
23	01-0526-19	Heat Exchanger Gate
24	03-5264	Z-Lock 25-1/2"
25	06-5263	Heat Exchanger Rod
26	05-0005	Manual Draft Butterfly
27	06-0221	Stainless Steel Cotter Pin

## BASIC UNIT FOR MODEL 2900

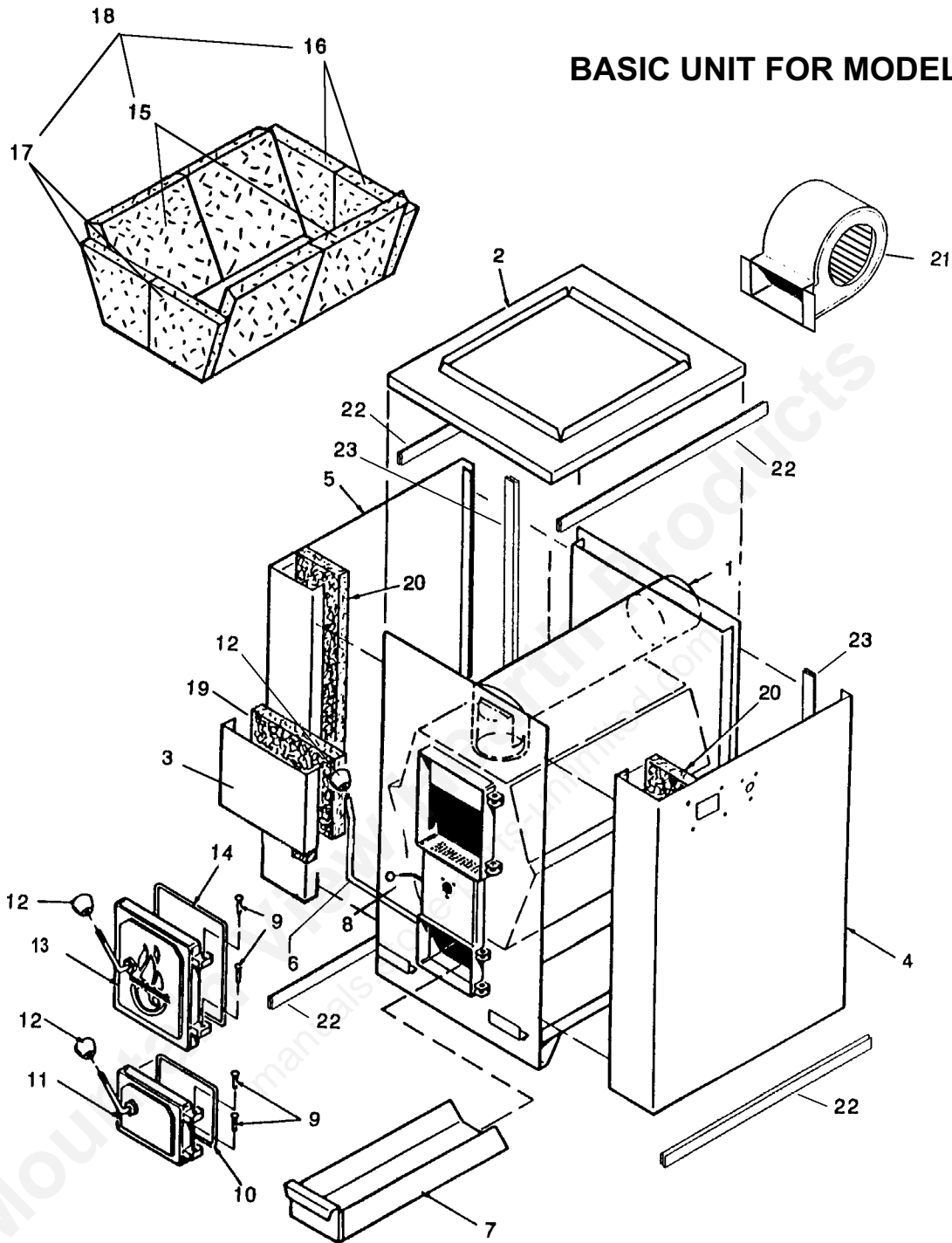

KEY NO.	PART NO.	DESCRIPTION	KEY NO.	PART NO.	DESCRIPTION
1	01-2900	Welded Assembly	13	02-2901	Fuel Door
2	03-2901	Shroud - Top	14	06-2902	Fuel Door Gasket
3	03-2904	Shroud - Front	15	07-2901	Side Brick Kit (4 pc.)
4	03-2902	Shroud - Right Side	16	07-2902	Rear Brick Kit (2 pc.)
5	03-2903	Shroud - Left Side	17	07-2903	Front Brick Kit (2 pc.)
6	05-2908	Shaker Handle	18	07-2900	Complete Brick Kit
7	06-1001	Ash Pan	19	06-2907	Insulation - Front
8	06-1013	80/20 Selector Knob	20	06-2906	Insulation - Side
9	06-0200	1/4" Door Pin	21	08-0005	Circulation Blower
10	06-2903	Ash Door Gasket	22	03-2905	Z-Lock 28-1/2"
11	02-2902	Ash Door	23	03-2906	Z-Lock 44-3/4"
12	06-1014	Handle Knob (Large)			

# BASIC UNIT FOR MODEL 4000

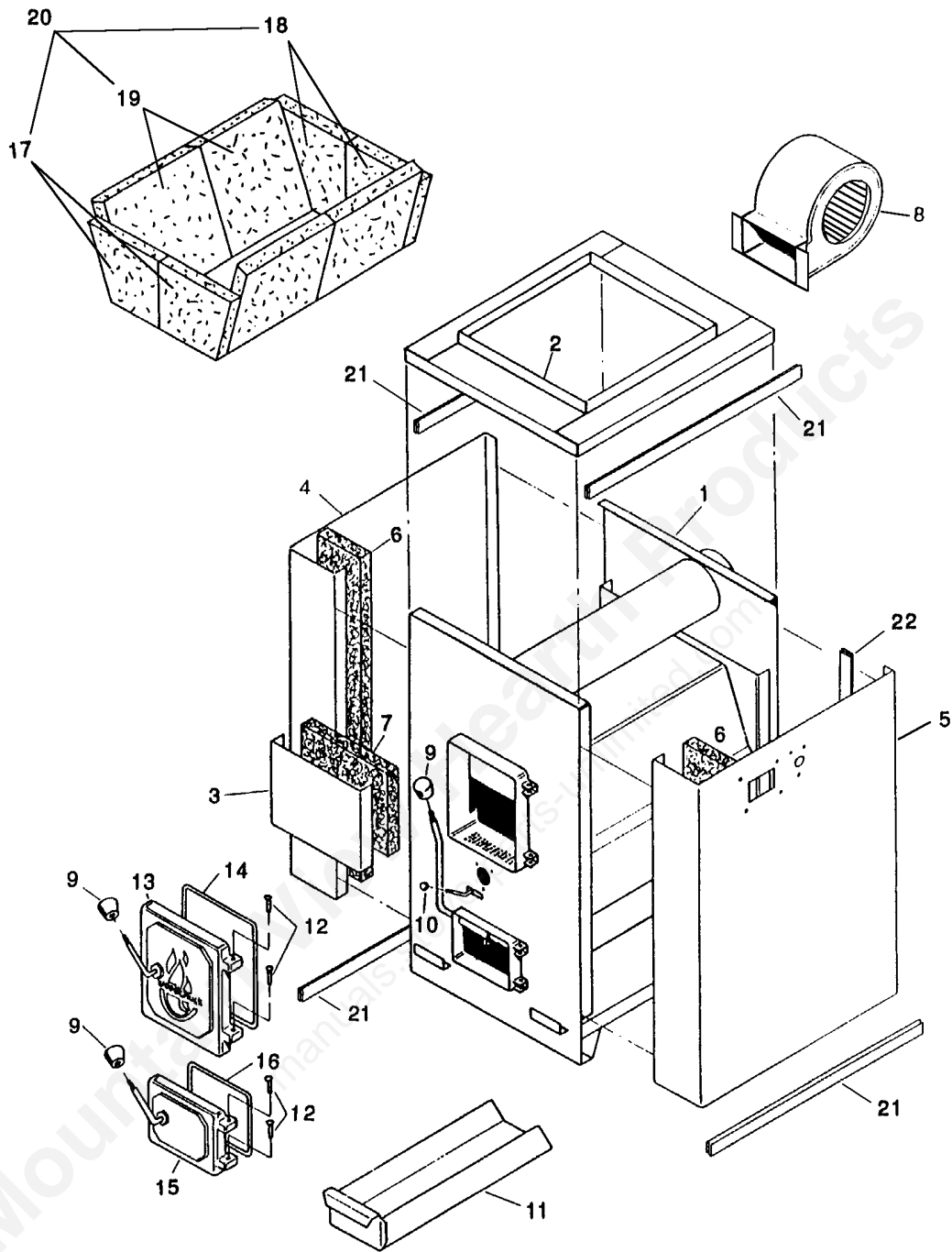

KEY NO.	PART NO.	DESCRIPTION	KEY NO.	PART NO.	DESCRIPTION
1	01-4000	Welded Assembly	12	06-0200	Door Pin
2	03-4001	Shroud - Top	13	02-2901	Fuel Door
3	03-2904	Shroud - Front	14	06-2902	Fuel Door Gasket
4	03-4003	Shroud - Left Side	15	02-2902	Ash Door
5	03-4002	Shroud - Right Side	16	06-2903	Ash Door Gasket
6	06-4001	Insulation - Side	17	07-4003	Front Brick Kit (2 pc.)
7	06-2907	Insulation - Front	18	07-4002	Rear Brick Kit (2 pc.)
8	08-0005	Circulation Blower	19	07-4001	Side Brick Kit (4 pc.)
9	06-1014	Handle Knob (Large)	20	07-4000	Complete Brick Kit
10	06-1013	80/20 Selector Knob	21	03-4004	Z-Lock 34-1/4"
11	06-1001	Ash Pan	22	03-4005	Z-Lock 48"

## #05-5260-OPTIONAL SHAKER GRATE FOR MODEL 526

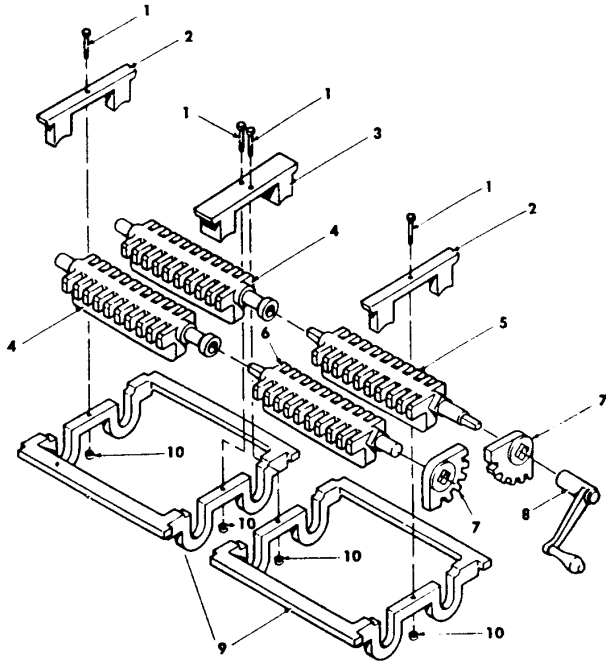

KEY NO.	PART NO.	DESCRIPTION
1	801-2520-1.25Z	1-1/2x1/4 Bolt
2	05-5265	End Retainer (S-5)
3	05-5266	Center Retainer (S-6)
4	05-5268	Rear Bar, Female (S-3)
5	05-5263	Front Bar, w/Extension (S-2-1)
6	05-5262	Front Bar, Male (S-2)
7	05-5264	Gears (S-4)
8	05-5267	Handle (S-7)
9	05-5261	Front Frame (S-1)
10	814-2520-Z	1/4 Lock Nut

## #05-2900 SHAKER GRATE FOR MODELS 2900/4000

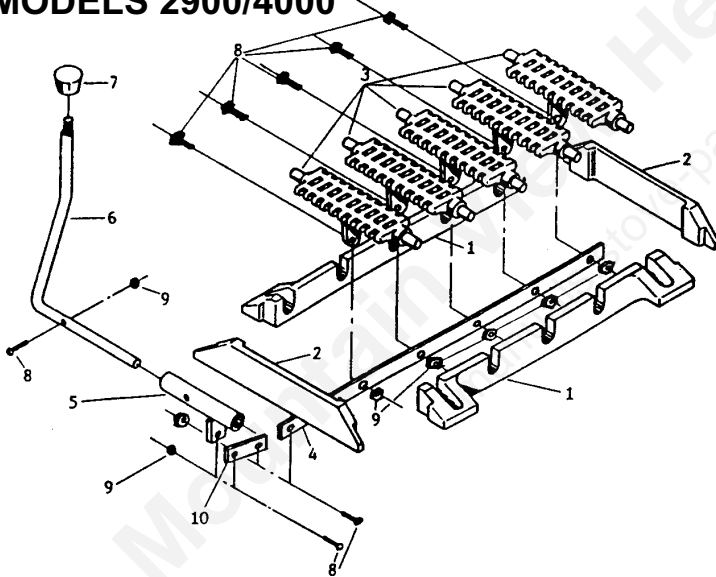

KEY NO.	PART NO.	DESCRIPTION
1	05-2902	Side Rail (W-9)
2	05-2903	End Rail (W-10)
3	05-2904	Shaker Bar (CC-130)
4	05-2905	Shaker Rail (WC-2900)
	05-4001	Shaker Rail (WC-4000)
5	05-2906	Sleeve (WC-2900)
	05-4003	Sleeve (WC-4000)
6	05-2908	Handle (WC-2900) E423
	05-2907	Handle (WC-4000)
7	06-1014	Knob
8	801-2520-1.5Z	1/4x1-1/2 Bolt
9	814-2520-Z	1/4 Lock Nut
10	05-2901	Linkage

## FILTER BOX

KEY NO.	PART NO.	DESCRIPTION
	<b>526</b>	
	<b>2900/4000</b>	
1	04-2900-6	Door
2	04-5260-7	Cabinet Assy.
3	NA	Mounting Cleat
4	04-5260	Complete Filter Box

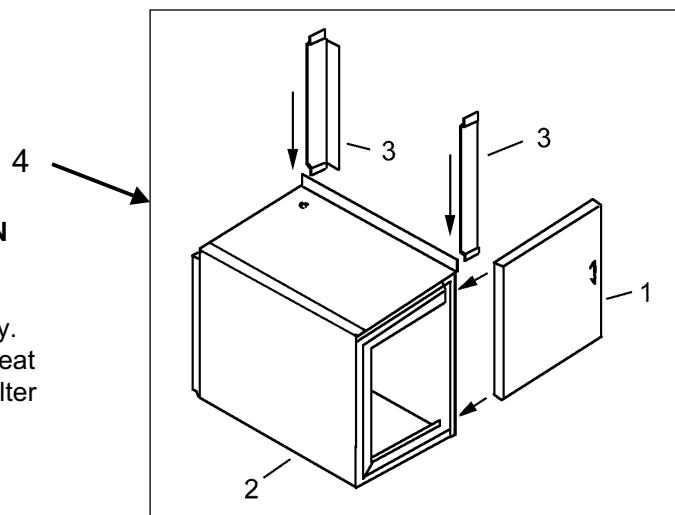

# CIRCULATING BLOWER

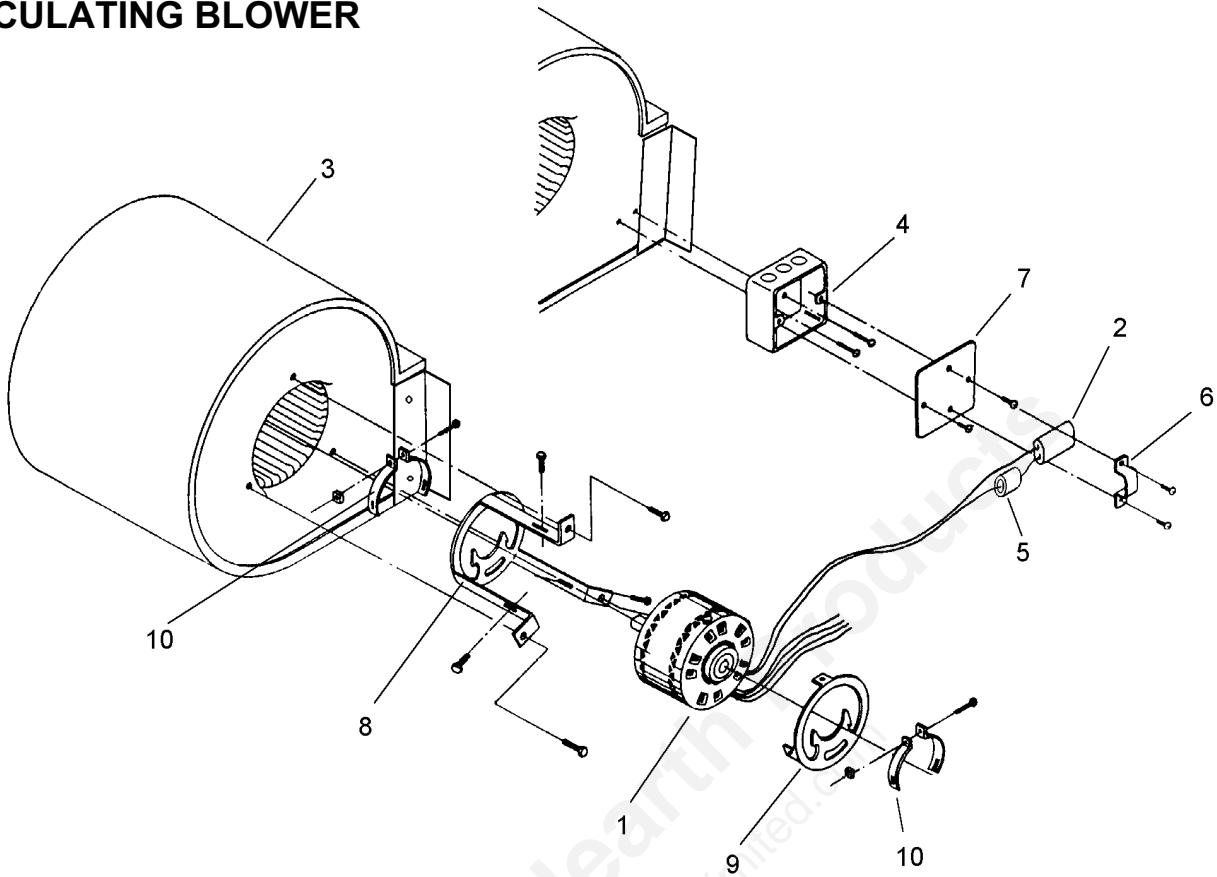

## #08-0100 COMFORT CONTROL

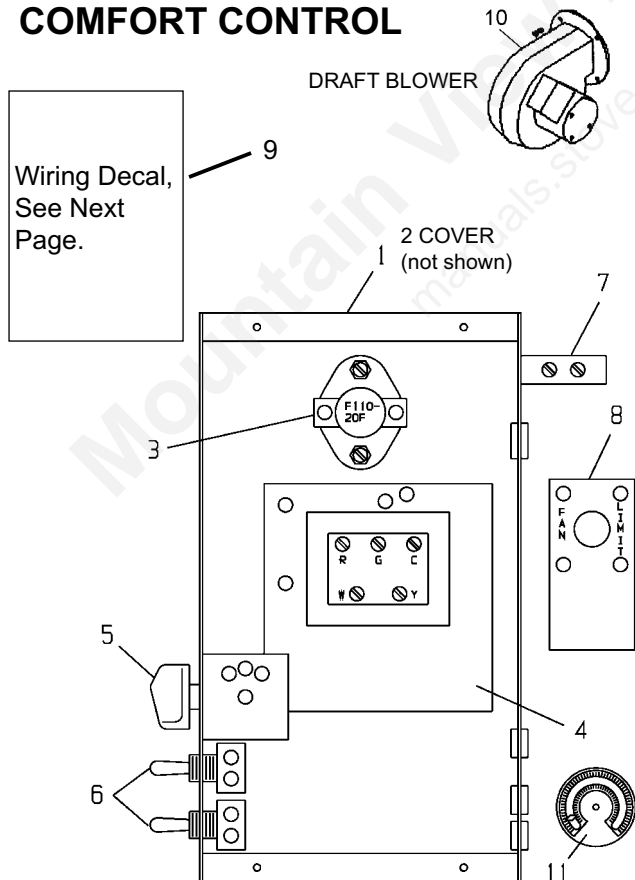

## #08-0090 COMPLETE BLOWER ASSY.

KEY NO.	PART NO.	DESCRIPTION
1	08-0001	Motor
2	08-0002	Capacitor
3	08-0005	Blower Assembly (no motor)
4	08-0048	Electrical Connection Box
5	08-0004	Capacitor Boot
6	08-0003	Capacitor Bracket
7	08-0049	Electrical Box Cover
8	08-0005-2	Large Motor Mount Bracket
9	08-0005-3	Short Motor Mount Bracket
10	08-0005-4	Motor Clamps

KEY NO.	PART NO.	DESCRIPTION
1	08-0100-1	Box Enclosure
2	08-0100-3	Cover
3	08-0029	Therm-O-Disc
4	08-0017	Fan Relay Center
5	08-0026	3 Speed Switch
6	08-0089	Switch Toggle
7	08-0106	Terminal Strip
8	08-0015	Fan Limit Control
9	462900-8	Wiring Decal
10	08-0006	60 CFM Draft Blower
11	08-0084	Flue Temperature Gauge

# 46-2900-8 Wiring Diagram

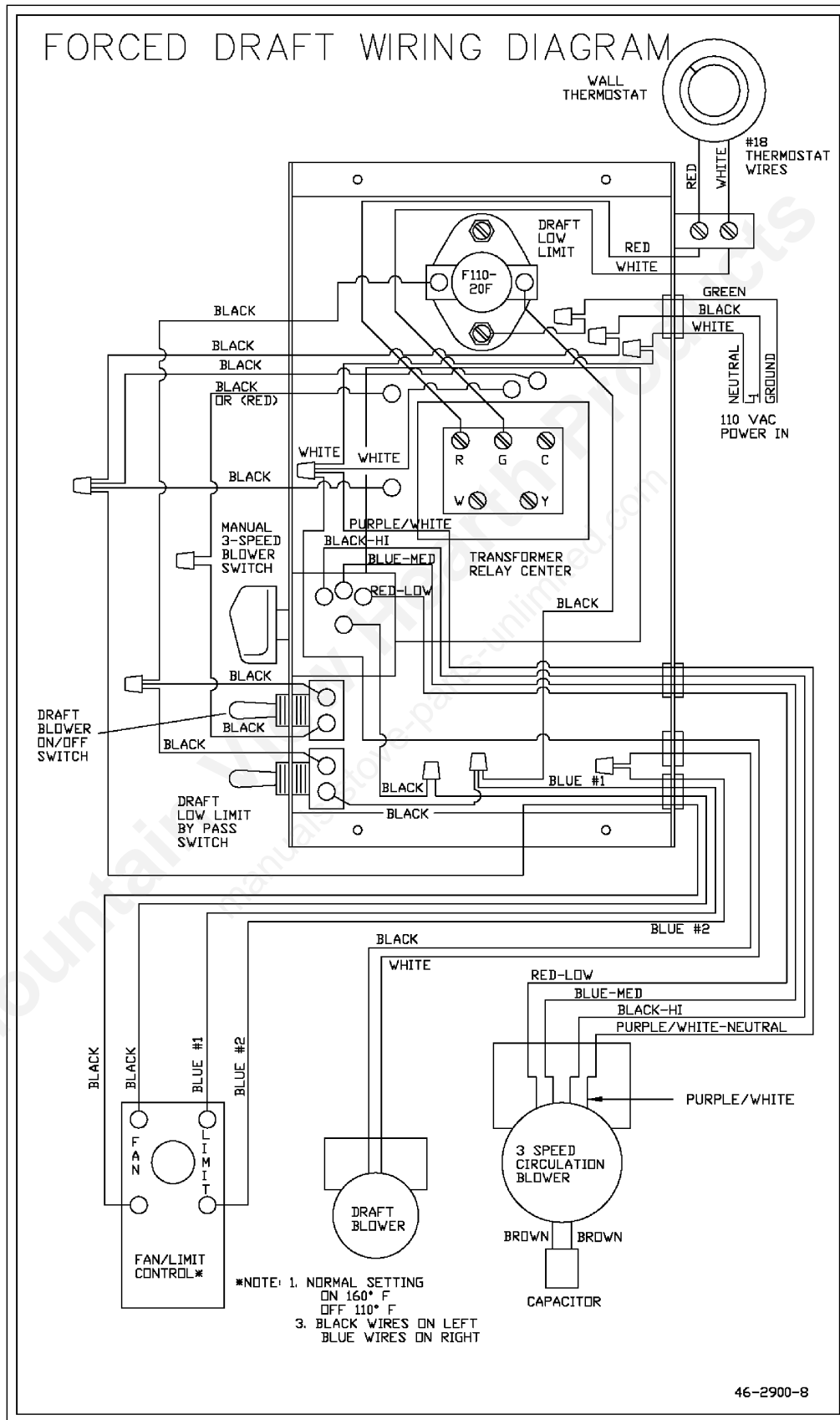

## PERSONAL DATA INFORMATION FOR FUTURE REFERENCE

Model No. Of Unit	_____	Date Of Purchase	_____
Serial No. Of Unit	_____	Date Of Installation	_____
Dealer Name	_____	Name Of Installer	_____
Address	_____	Address	_____
Phone	_____	Phone	_____

### Equipment Options

- Filter Box
- Shaker Grate
- Domestic Coil

Mountain View Hearth Products  
manuals.stove-parts-unlimited.com

This Page Intentionally Blank

Mountain View Hearth Products  
manuals.stove-parts-unlimited.com

## LIMITED WARRANTY

### What is covered:

Meyer Manufacturing Corporation warrants to the original owner only, all parts in this model Woodchuck solid fuel appliance to be free from defects in material and workmanship.

### For how long:

For a period of one (1) year (from date of purchase) of normal use.

### Additional Coverage:

In addition, Meyer Manufacturing Corporation separately warrants the firebox for an additional five (5) years on a prorated basis. Proration will begin with the 13th month of ownership.

### Exclusions:

The firebrick and grates which are expendable and replaceable parts as well as cosmetic changes due to normal operation are not covered.

### What the Customer must do:

In the event a Woodchuck solid fuel appliance is defective in workmanship or materials, Meyer Manufacturing Corporation will repair or, at our option, replace the defective part. To obtain a remedy the purchaser must ship the part(s), freight prepaid, to:

MEYER MANUFACTURING CORPORATION  
P.O. Box 405  
Dorchester, Wisconsin 54425

All claims must be accompanied by a proof of purchase substantiating date of purchase. In the event date of purchase cannot be obtained, Meyer Manufacturing Corporation will assume it to be 90 days after date of production.

### What We will do and will not do:

Meyer Manufacturing Corporation will ship the repaired or replacement part to the Purchaser freight collect. The Purchaser is responsible for service, removal and reinstallation labor cost.

### Other Conditions:

The warranty applies only if the unit is installed and operated as recommended in the owners manual and used with a class "A" all-fuel chimney. The draft from the chimney must be .04 to .06 inches W.C. draft. The warranty will not apply if the unit is used for commercial purposes, if damage is caused by abuse, accident, improper installation, overheating or negligence, or from an attempt to repair the unit by any person not expressly authorized by Meyer Manufacturing Corporation to do the repair.

### Limit of Obligation:

No one is authorized to make any other warranties on behalf of Meyer Manufacturing Corporation. We will NOT be responsible for any promises NOT in our warranty. Any special, incidental or consequential damages are excluded to the extent permitted by law. Any implied warranty, including merchantability or fitness for a particular purpose shall NOT extend beyond the warranty stated above.

### State Law Rights:

Some states do not allow limitations on how long an implied warranty lasts, so the above limitations may not apply to you. This warranty gives you specific legal rights and you may also have other rights which vary from state to state.



P.O. Box 405 — Dorchester Wisconsin 54425

This card is to be sent to your Home Owners Insurance company for their records and your protection.

Name \_\_\_\_\_  
Address \_\_\_\_\_  
City \_\_\_\_\_ State \_\_\_\_\_ Zip \_\_\_\_\_  
Home Owners Policy No. \_\_\_\_\_

Card must be completed and mailed within 10 days of the purchase of your Woodchuck for your warranty to come into affect.

Name \_\_\_\_\_  
Address \_\_\_\_\_  
City \_\_\_\_\_ State \_\_\_\_\_ Zip \_\_\_\_\_  
Date Purchased \_\_\_\_\_ Date of Instanation \_\_\_\_\_  
Serial No. \_\_\_\_\_ Model No. \_\_\_\_\_ Price Paid \_\_\_\_\_  
Installer Name \_\_\_\_\_  
Address \_\_\_\_\_  
City \_\_\_\_\_ State \_\_\_\_\_ Zip \_\_\_\_\_  
Phone \_\_\_\_\_

Yes  No Have you ever owned a wood heater before?

MEYER MANUFACTURING CORPORATION  
Manufacturers Of Woodcoal Furnaces  
P.O. Box 405  
Dorchester, Wisconsin 54425

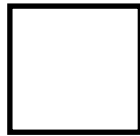

*Manufactured By*  
MEYER MANUFACTURING CORPORATION  
P.O. Box 405  
Dorchester, Wisconsin 54425

MEYER MANUFACTURING CORPORATION  
P.O. Box 405  
Dorchester, Wisconsin 54425

